

# RL550 Casefeeder Assembly and User Instructions

Dillon Precision, Inc.

---

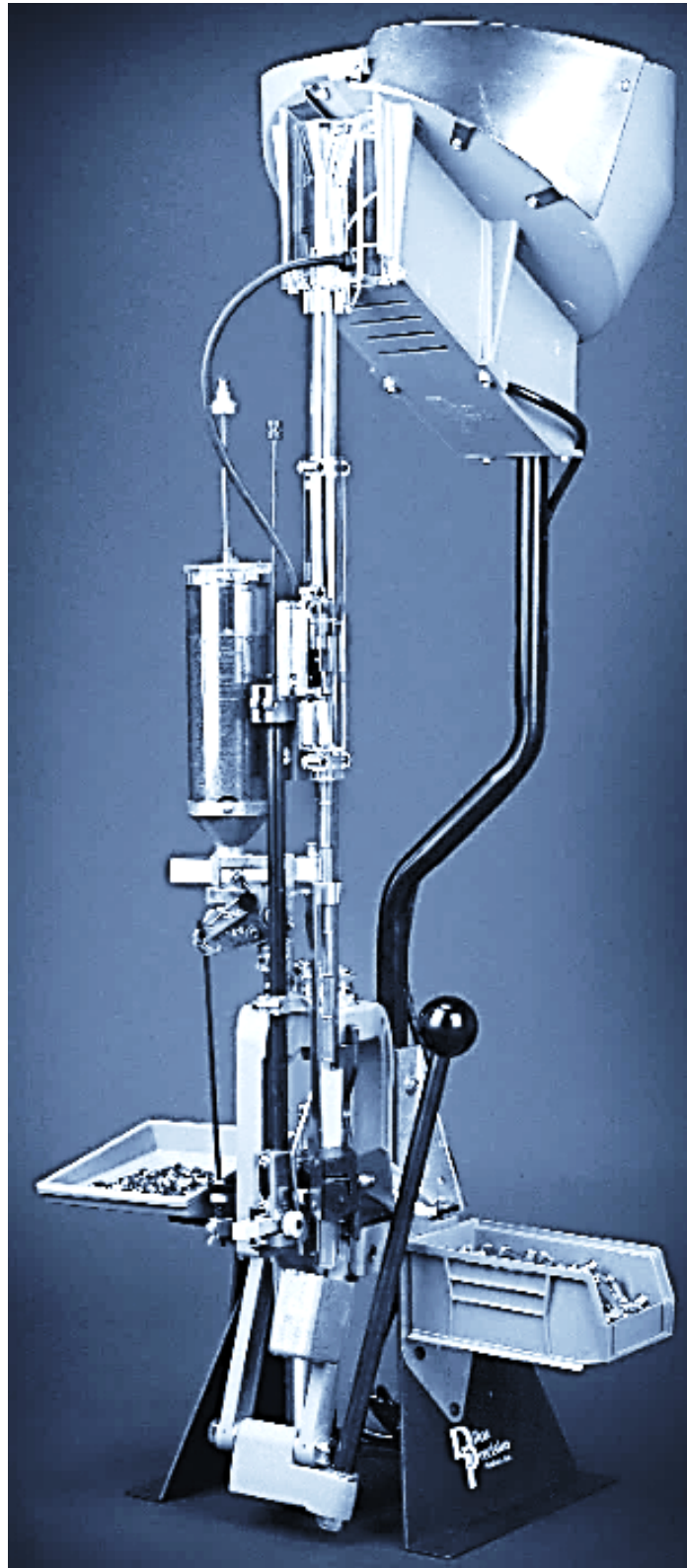

Copyright © 2021 by Dillon Precision, Inc.--All rights reserved. This publication is for personal use only. No part of this publication may be reproduced, distributed, or transmitted in any form or by any means, including photocopying, recording, or other electronic or mechanical methods, for commercial use without the prior written permission of Dillon Precision.

RL550C™ and RL550 Casefeeder Upgrade™ are trademarks of Dillon Precision Inc.

Rev. 2 Mar 2026

## **TABLE OF CONTENTS**

**MANDATORY USER SAFETY MINIMUM REQUIREMENTS—Page 4**

- 1. RL550 CASEFEEDER LIMITED LIFETIME WARRANTY—Page 5**
- 2. RL550 CASEFEEDER AVAILABLE CONFIGURATIONS—Page 5**
- 3. RL550 CASEFEEDER SHIPPING CONTENTS—Pages 6-7**
- 4. RL550C CASEFEEDER ASSEMBLY GUIDE—Pages 7-24**
- 5. SETUP PROCEDURES—Pages 24-26**
- 6. CONVERSION LIST AND PROCEDURES—Pages 27-28**
- 7. TROUBLESHOOTING RL550C—Page 29**
- 8. EXPLODED VIEWS AND PARTS IDENTIFIER—Pages 30-33**
- 9. NOTES--Page 34**

## DILLON PRECISION DISCLAIMER, EXPLANATION OF SAFETY WARNINGS, DILLON CONTACT INFORMATION

### DISCLAIMER

The material in this manual is for informational purposes only. The products it describes are subject to change without prior notice. Dillon Precision Inc. makes no representations or warranties with respect to this manual.

Dillon Precision Inc. shall not be liable for any damages, losses, costs or expenses, direct, indirect or incidental, consequential or special, arising out of, or related to the use of or the inability to use the products described herein. Read this manual before using this product. Failure to follow the instructions and safety precautions in this manual can result in serious injury or death. Keep this manual in a safe location for future reference.

### EXPLANATION OF SAFETY WARNINGS

#### DANGER!

Danger! indicates a hazard with a high level of risk that if not avoided, will result in death or serious injury.

#### WARNING!

Warning! indicates a hazard with a medium level of risk that if not avoided, could result in death or serious injury.

#### CAUTION!

Caution! indicates a hazard with a low level of risk that if not avoided, could result in minor or moderate injury.

### Dillon Contact Information

Dillon Precision Inc.

8009 E. Dillon's Way

Scottsdale, AZ 85260

480-948-8009 1-800-223-4570

FAX 480-998-2786

Website: [www.dillonprecision.com](http://www.dillonprecision.com)

E-mail: [dillon@dillonprecision.com](mailto:dillon@dillonprecision.com)

### Sales, Technical Support and Customer Service

800-223-4570

### Document Revisions

Date	Version Number	Document Changes
1-28-2021	0	Initial Release Temporary Manual
5-13-2023	1	Change the Shoulder Bolt Number on page 31 to 62212
3-31-2026	2	Added New Casefeed Post Mount Bracket PN18923

## **MANDATORY SAFETY PRECAUTIONS—MUST BE READ**

- *Reloading ammunition and handling reloading components can be hazardous. Accidents and errors may occur during the reloading process.*
- *Dillon Precision, Inc. designed the RL550C with user safety as a priority and has implemented all measures known to the company to help ensure the RL550C is operated as safely as possible.*
- *Dillon Precision, Inc. cannot guarantee the complete safety of any RL550C user. To reduce risk, exercise sound judgment at all times and, at a minimum, comply with the following safety requirements.*
- *KNOWLEDGE: Study and understand the basic processes and specifications for reloading ammunition using reputable sources and publications from established bullet and powder manufacturers, including Sierra, Hornady, Speer, and Alliant Powders. Consult recognized reloading manuals, such as the Lyman Reloading Manual.*
- *EYE AND EAR PROTECTION: Never operate the RL550C without appropriate eye and ear protection.*
- *ATTENTION: Give the reloading process your full and undivided attention. Do not watch television, use the internet, or engage in conversation while reloading. Reloading requires continuous focus.*
- *INTERRUPTIONS: If you are interrupted for any reason, inspect the cases at every station before resuming operation. Confirm precisely which steps have and have not been completed to ensure the process remains correct.*
- *SMOKING / IMPAIRMENT: Do not smoke or allow smoking in the reloading area. Do not permit open flames. Do not reload if you have consumed alcohol or are impaired in any manner.*
- *SAFETY DEVICES / MODIFICATIONS: Do not remove any safety device or modify the reloader in any way. Keep components and ammunition out of the reach of children.*
- *LEAD: Most bullets contain lead, which may or may not be exposed. Ensure adequate ventilation when handling bullets or when shooting. Lead exposure may cause birth defects, reproductive harm, and cancer. Wash hands thoroughly after handling lead components or after shooting.*
- *POWDERS: Many propellants are used in reloading and are generally designated for rifle, pistol, or shotgun applications. Powder selection must be appropriate for the caliber, bullet weight, and bullet type being loaded. Great care must be used when selecting and measuring powder. Always follow guidance from established bullet and powder manufacturers. Using an incorrect powder, an incorrect powder charge, or mixing powders may cause serious injury. Never mix powders. Store powder only in its original container. Do not keep more than one powder type in the reloading area at a time; preferably, store powders in a separate room. Observe all maximum load warnings.*
- *PRIMERS: Primers contain a small amount of shock-sensitive compound that detonates when struck or accidentally crushed. Never force primers. If primers become stuck during operation, carefully disassemble the reloader and gently remove the obstruction. Never attempt to clear primers stuck in the primer pickup tube or primer magazine tube. Do not insert any rod or object into these tubes to dislodge primers, as primers may “chain detonate.” If primers become stuck in the magazine or pickup tubes, flood the tube with penetrating oil (e.g., WD-40), discard the tube, and contact Dillon for a free replacement. Never deprime a cartridge case containing a live primer, as this may cause serious injury or death. Never attempt to further seat primers on a loaded cartridge. Use only the primer specified for the application being loaded.*
- *BLACK POWDER: Do not use black powder or black powder substitutes in any Dillon Powder Measure. Doing so may result in severe injury.*
- *LOAD DATA AND CARTRIDGE OVERALL LENGTH: Use only recommended load specifications from reloading manuals and information supplied by established component manufacturers. Avoid maximum loads listed in manuals. Exercise extreme care to prevent a double charge. Dillon has no control over the components selected or the specifications used with Dillon equipment, and no responsibility is implied or assumed for results arising from the use of, or inability to use, such components or load data.*
- *QUALITY CHECKS: At a minimum, perform periodic quality checks every 50–100 rounds, particularly verification of the powder charge.*
- *LABELING: Properly label all reloaded ammunition, including overall length; bullet manufacturer, type, and weight; primer manufacturer and type; powder manufacturer, type, and charge weight; and the date loaded.*
- *RELOADING AREA: The reloading area should be well lit, dry, and comfortable, and free from drafts or breezes.*
- *PATIENCE AND OBSERVATION: Users should be able to achieve published, conservative loading rates without difficulty. Operate smoothly and steadily, and do not rush the process. If something does not look right, sound right, or feel right, stop immediately and evaluate the situation. If the issue is not apparent, contact Dillon Technical Support at (800) 223-4570 or visit the troubleshooting section at [www.dillonprecision.com](http://www.dillonprecision.com)*

## 1. RL550C CASEFEEDER LIMITED LIFETIME WARRANTY

Dillon Precision Inc. warrants the RL550C Casefeeder for the life of the system against defects in material and workmanship except for the following that Dillon Precision Inc. warrants against defects in material and workmanship for one year from the date of shipment:

- Casefeed Motor
- Casefeed Controls

Dillon Precision Inc. will either repair or replace any part(s) that prove defective. Dillon Precision Inc. Will provide repaired or replacement parts at Dillon's choice on an exchange basis. This limited warranty does not cover any damage to the product that results from improper installation, accident, abuse, misuse, natural disaster, insufficient or excessive electrical supply, abnormal mechanical or environmental conditions, or any unauthorized disassembly, repair or modification. This limited warranty shall not apply if: (i) the product was not used in accordance with any accompanying instructions, (ii) the product was not used for its intended function. A part(s) replaced under warranty does not restart the warranty period.

## 2. RL550C CASEFEEDER AVAILABLE CONFIGURATIONS:

### 2.1. 110/220VAC Models

PN14450 Large Pistol

PN14451 Small Pistol

### 2.2. Available Casefeed Plates:

Small Pistol Casefeed Plate—PN21073

Large Pistol Casefeed Plate—PN21072

### 2.3. NOTE—

- ***The RL550 Casefeed System can only be used with the listed Pistol Calibers***
- *Available Conversion Kits are required for each Caliber*
- *Only one size Casefeed Plate is included*

### 3. RL550C CASEFEEDER SHIPPING CONTENTS

#### 3.1. Remove the following items from the shipping box:

ITEM	PART #	DESCRIPTION
1	96001	550 CF UPPER BOWL ASSEM
2	18910	550 UPPER CF TUBE
3	18908	550 LOWER CF TUBE
4	18911	550 CASEFEED CAM
5		CASEFEED ADAPTER, NOT INCLUDED
6	96002	550 CF LOWER FEEDER ASSEM
7	14530	550 PLATFORM MOUNTING SCREWS
8	17124	550/900 MOUNTING POST
9	18907	550 CF POST MOUNT, CAST
10	18923	550 CF POST MOUNT, FORMED
11	14457	550 CF MOUNTING HARDWARE

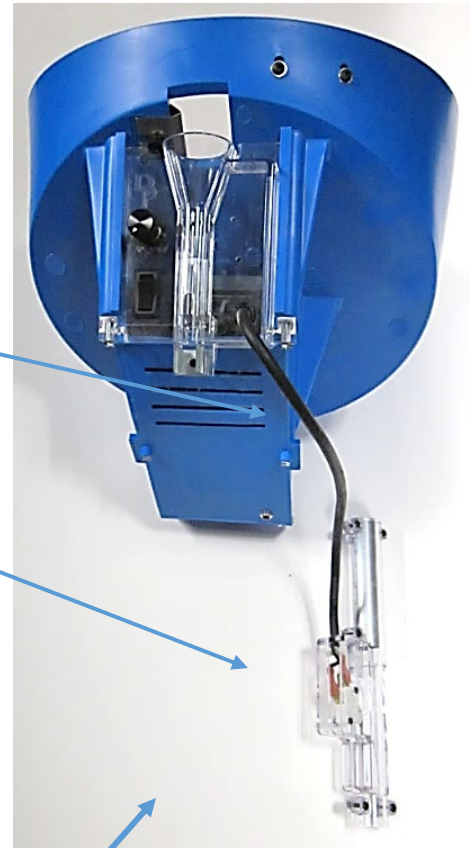
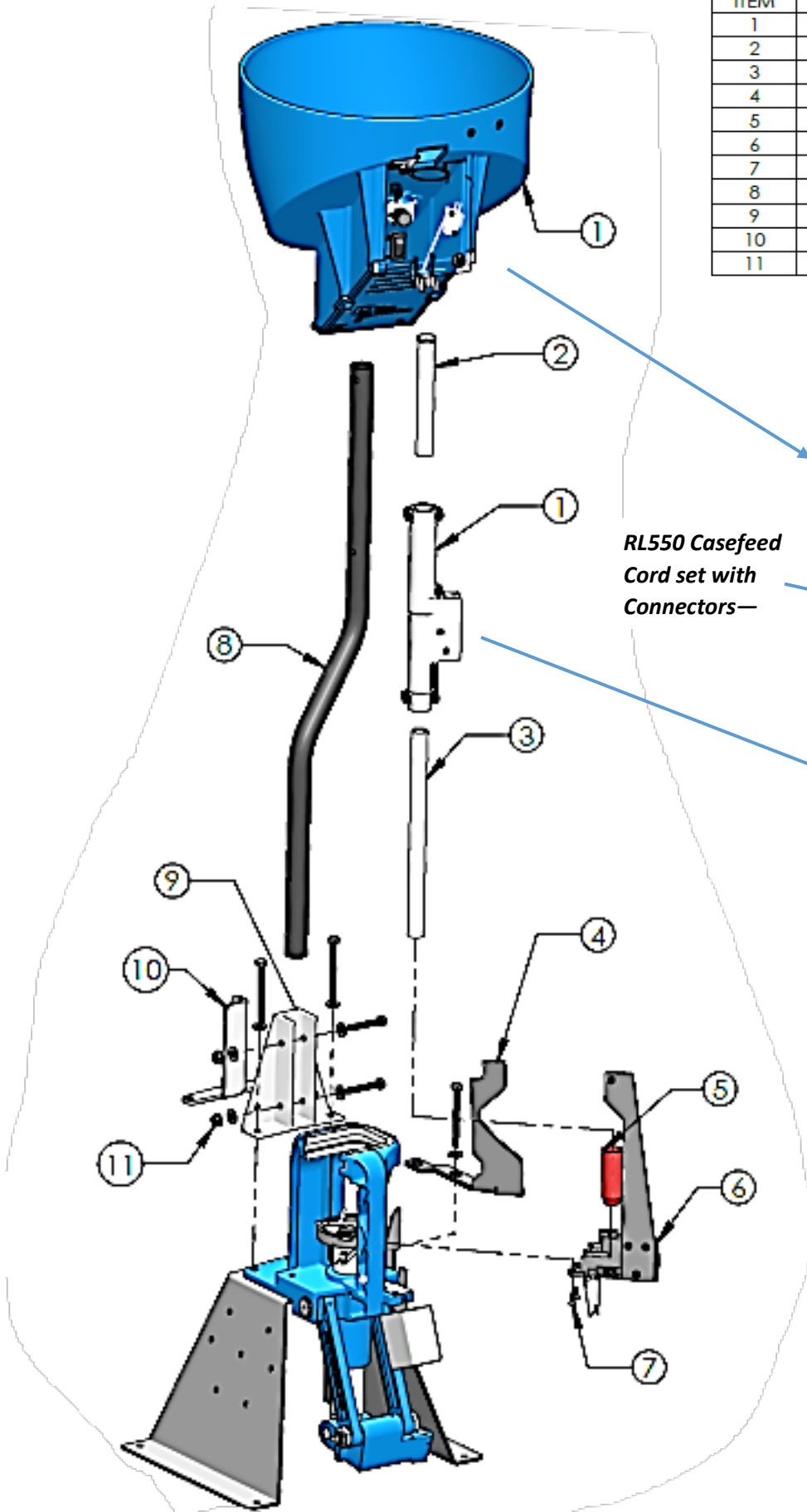

*RL550 Casefeed  
Cord set with  
Connectors—*

*RL550 CF Variable Speed Casefeed  
Bowl Assembly PN96001—Bowl,  
Cord and Switch Housing/Feed tube*



**Included Variable Speed Casefeed Power  
Supply and Adapters**

3.2. Locate the Hardware Kit PN14457 and acquire two 7/16" wrenches

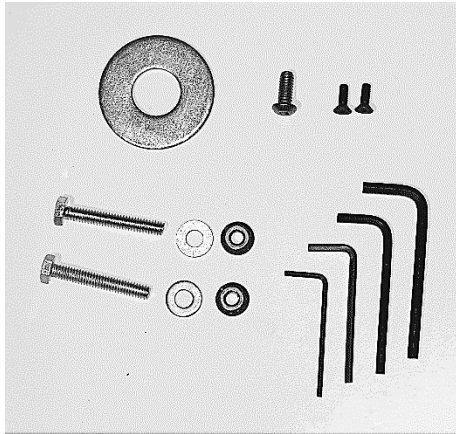

Hardware Kit Contents	
Description	Qty.
1/4 - 20 x 1 3/4 Hex Cap Screw	2
1/4 washer	2
1/4 -20 Flanged Nut	2
8-32 x 1/2 Countersunk Flathead	2
1/4 -20 x 5/8 Button Head Cap Screw	1
13/16 Washer	1
3/16 Allen Wrench	1
5/32 Allen Wrench	1
1/8 Allen Wrench	1
3/32 Allen Wrench	1

6.0 RL550C CASEFEEDER ASSEMBLY GUIDE

6.1 Disassemble your RL550—Remove the Primer System, the Powder System and Toolhead as described below:

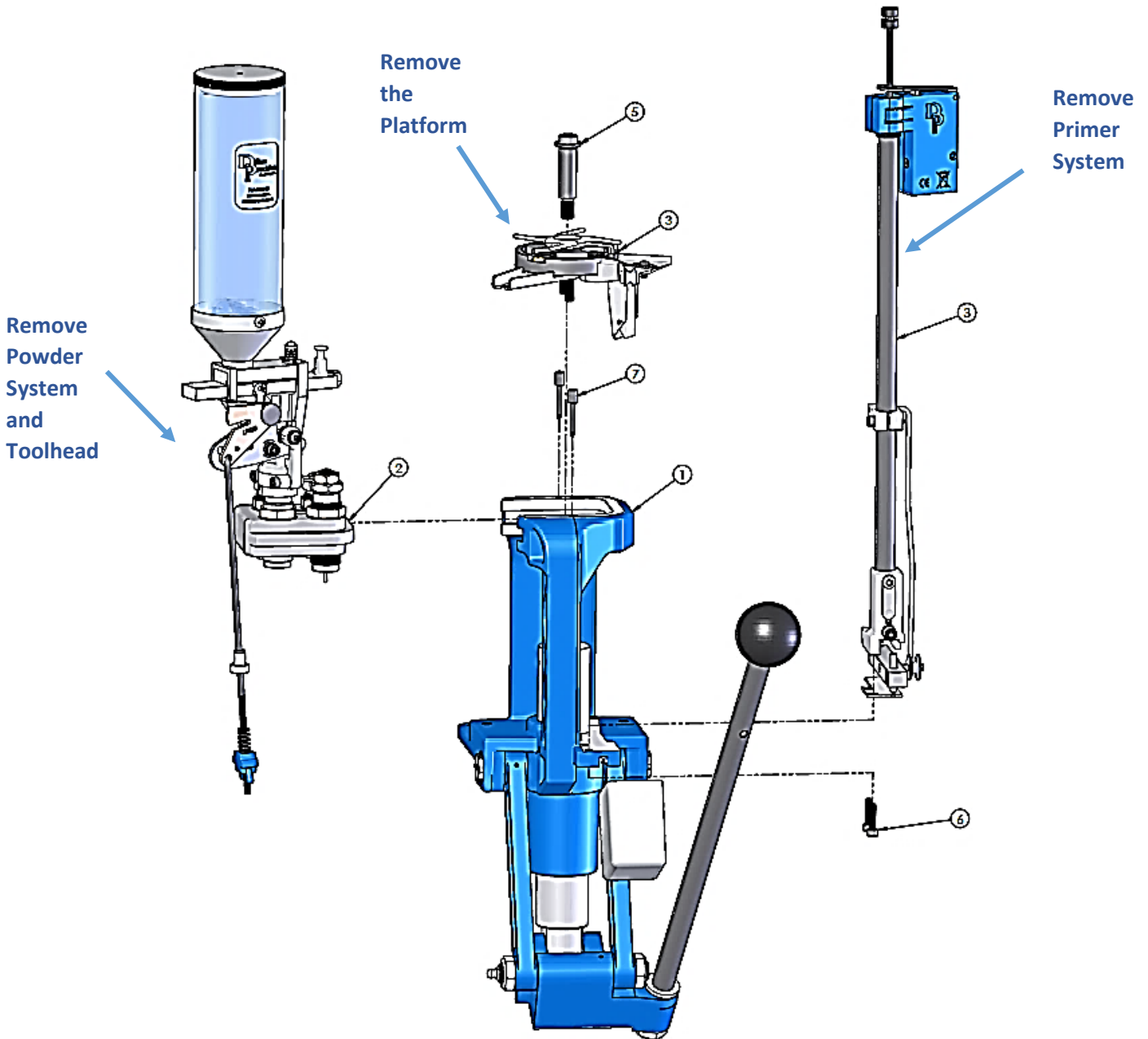

**6.1.1 Disconnect the Failsafe Rod and Remove the Power Measure and Toolhead.**

**Pull Failsafe Bushing down out of Bracket**



**Remove Toolhead Pins and Remove Toolhead with Powder Measure**

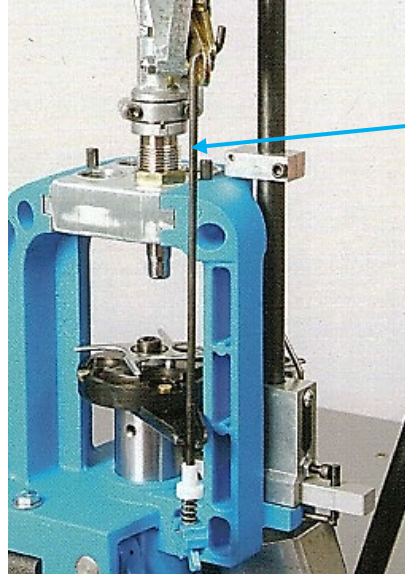

**6.1.2 Remove the Operating Rod by lowering the Operating Handle partway down, pulling back on the Primer Slide, disengaging and removing the Operating Rod.**

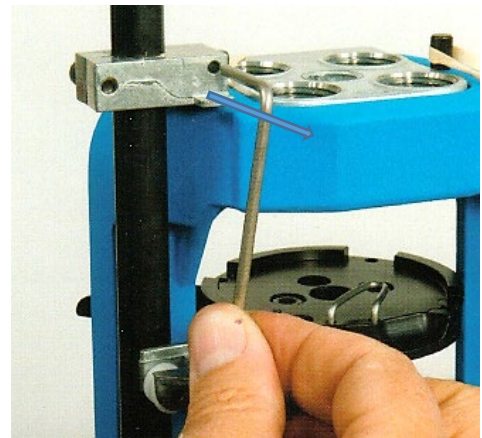
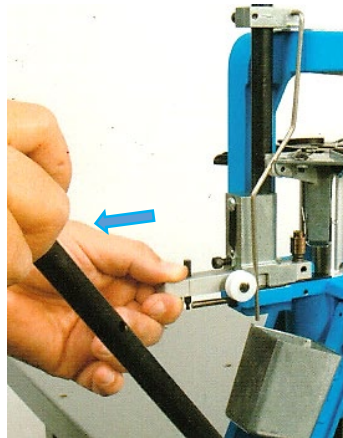

**6.1.3 Unhook the Primer Slide Return Spring from the Prime Slide. Remove the two Primer Housing attachment Socket Head Screws with a 5/32" Allen wrench.**

**Remove Spring and let hang down**

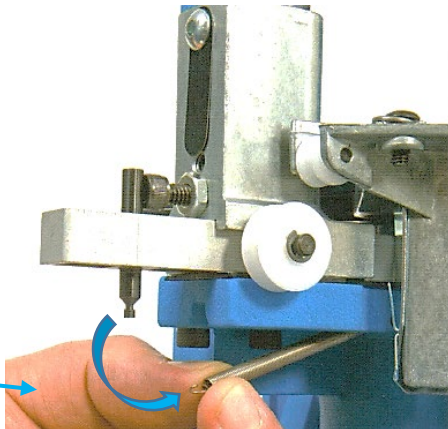

**Remove the two Primer Housing Attachment Screws**

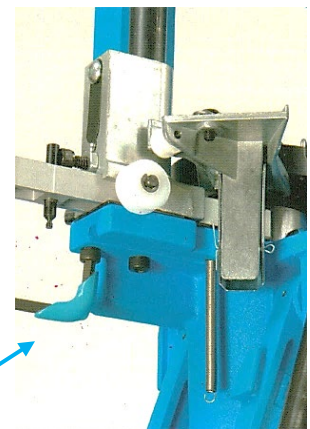

6.1.4 Lower the Operating Handle partially down while holding onto the Primer Housing Assembly. Remove the Primer Housing Assembly and the Follower Rod and “pour out” any primers left in the Magazine Tube. **WARNING!** --Any primers left in the Magazine Tube will fall out inside the Magazine Shield when you pull the Primer Magazine tube out.

Remove Primer Assembly and set aside

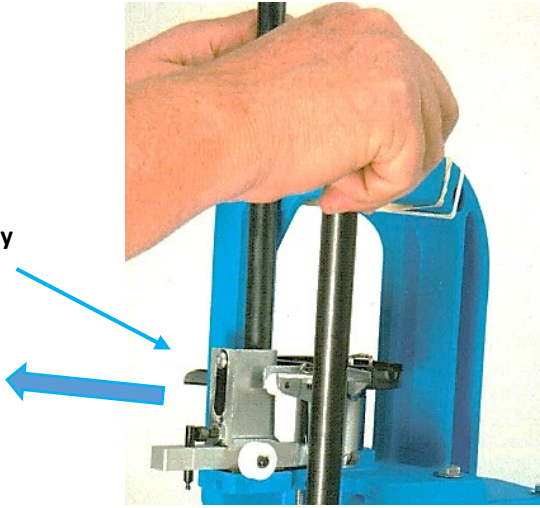

Remove Track bearing and set aside

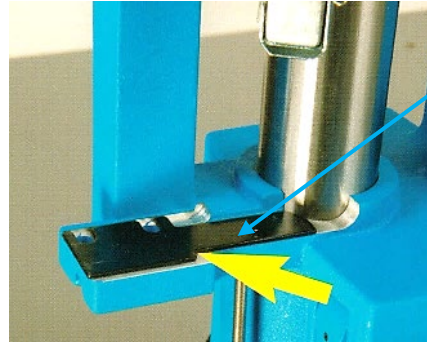

6.1.5 Remove the Cartridge Chute/Bin Bracket from the Strong mount if used.

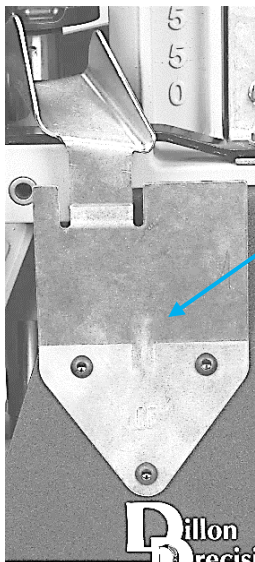

Remove Chute and Bin Bracket if a Strong Mount is installed

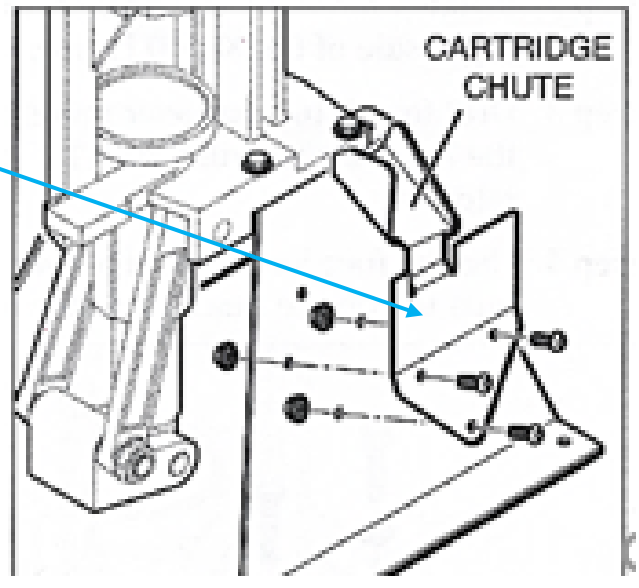

## 6.2 Remove the RL550 Platform (Reference Assembly Below)

ITEM	PART NUMBER	QTY.
1	13775_550 MAIN SHAFT	1
2	13923_250-28x440 BRASS DOG PT SET	1
3	13781_550 PLATFORM	1
4	13966_250-28x750 SHCS	2
5	13997_INDEX BALL SPRING	1
6	13891_375 INDEX BALL	1
7	13885_RETURN BRACKET	1
8	13631_550 ROLLER BRACKET REVISED	1
9	14001_PLATFORM ROLLER PIN	1
10	13899_SPENT PRIMER CHUTE	1
11	13998_062x1 SS COTTER	1
12	13926_STATION 1 LOCATOR	1
13	13719_8-32x375 BHCS	1
14	14530_8-32x500 FHS	2
15	13765_SMALL ROLLER RL550-XL750	1
16	13925_550 EJECTOR WIRE	1
17	LOCATOR BUTTON #1 *	3
18	13692_550 SHELLPLATE #1 *	1
19	13720_550 INDEX SPROCKET	1
20	13794_550 SHELLPLATE BOLT	1

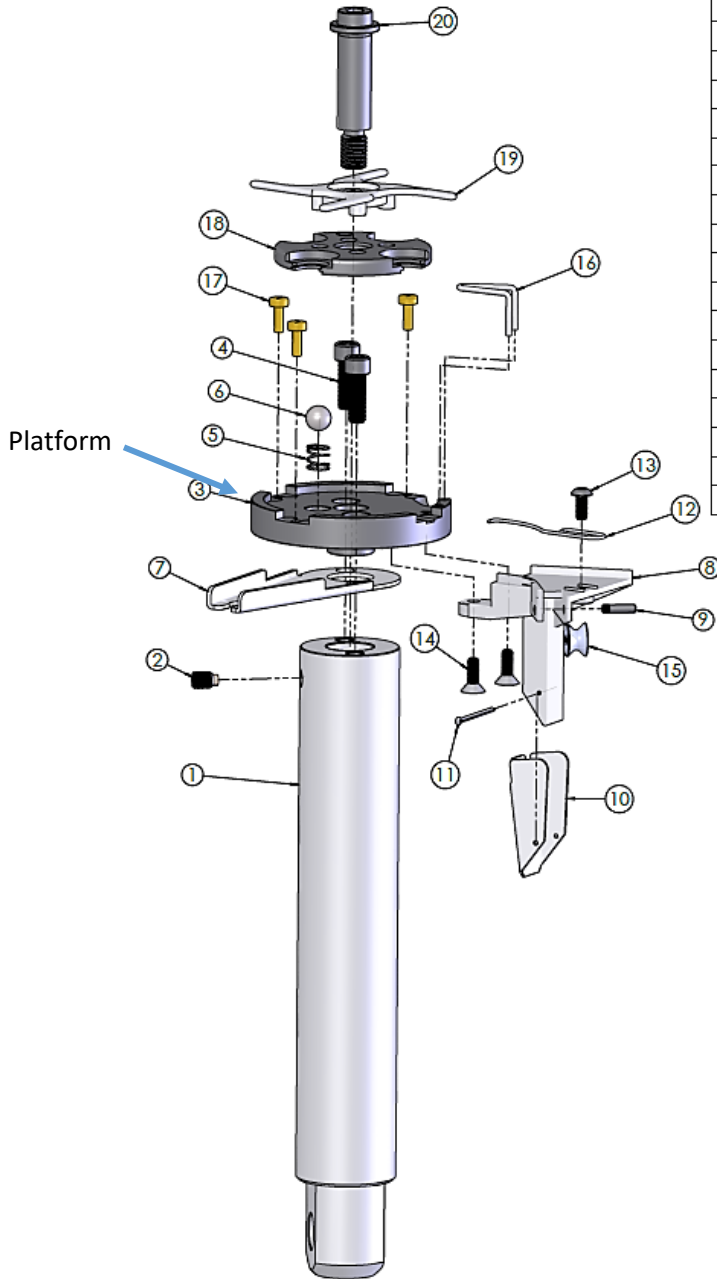

\* CALIBER SPECIFIC, SEE CONVERSION TABLE

### 6.2.1 Remove the three Locator Pins and loosen the Brass Tipped Set Screw on the side of the Mainshaft with the provided Allen Wrench.

Remove the three  
Locator Pins

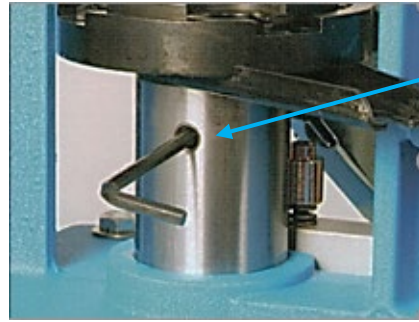

Loosen  
Shellplate Bolt  
Locking Set  
Screw

**6.2.2 Remove and store the Shellplate Bolt, Index Sprocket and Shellplate.**

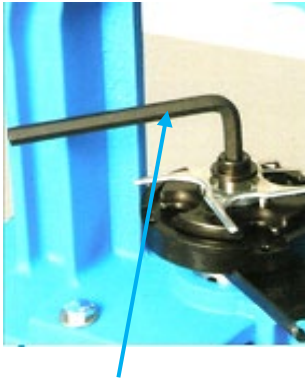

**Remove Shellplate Bolt**



**Remove Index Sprocket**



**Remove Shellplate**

**6.2.3 Remove and store the Index Ball, the Index Spring, the two Platform Mounting Screws and the Platform.**

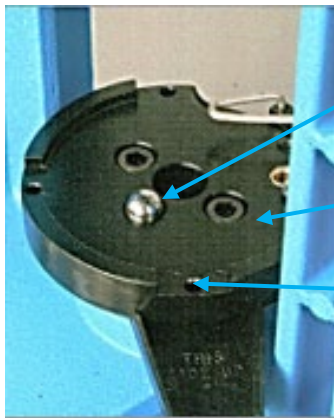

**Remove the Index Ball and Spring**

**Remove the two Socket Head Platform Mounting Screws with the supplied 3/16" Allen wrench**



**6.3 Assemble the RL550 Casefeeder to the existing RL550 Platform**

**6.3.1 Take the Platform removed from the RL550--set the Failsafe Bracket aside for reinstallation —item 7 in 6.2 above. Remove the Roller Bracket Assembly from the bottom of the Platform by removing the two Flat Socket head screws with supplied 3/32" Allen wrench and store the Roller Bracket.**

**Flat Socket Head Mounting Screws (2)**

**Existing RL550 Platform—bottom side**

**Roller Bracket—not used with RL550 Casefeeder**

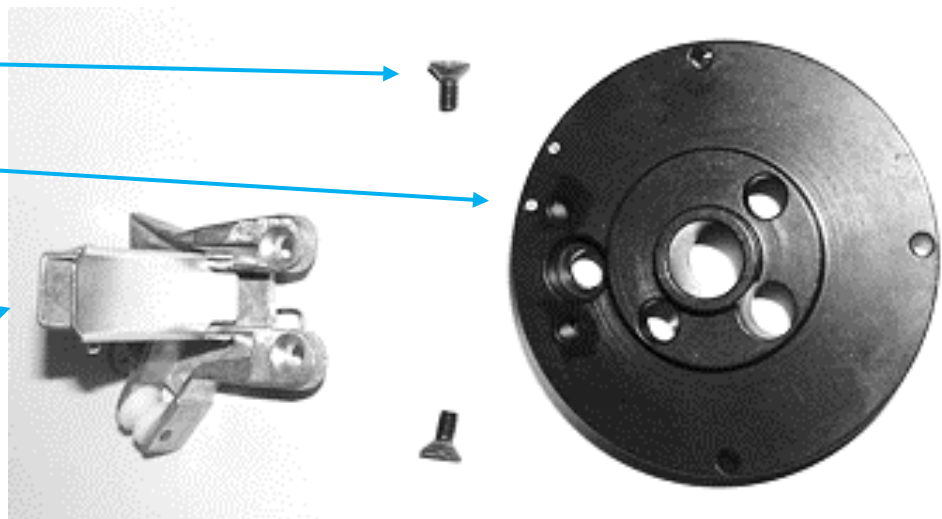

**6.3.2** Locate the RL550 CF Lower Feeder Assembly (PN 96002 below) from the shipment and attach it to the bottom of the RL550 Platform with the provided 8-32 x 1/2" Flat Socket Head Screws. Use one drop of blue Loctite on the threads of the Flathead Socket Screws. Tighten firmly using the provided 3/32" Allen wrench allowing the taper of the screws to position the Feeder Assembly.

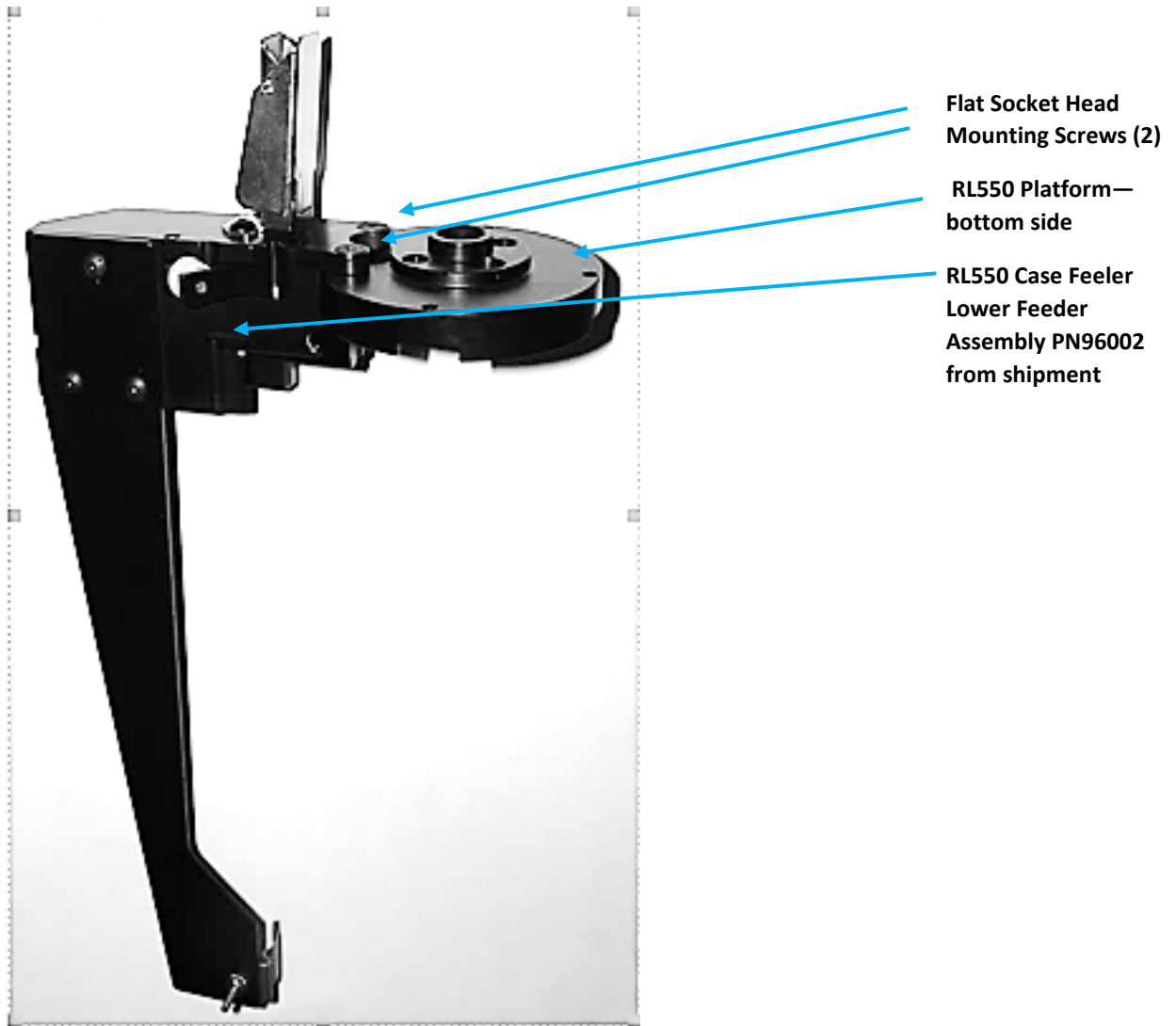

**6.3.3** Locate an “empty” RL550 Tool Head (PN13909). Install a standard Dillon Powder Die (PN20060) in the Station #1 position of the Toolhead. Insert the Supplied Alignment Tool (PN13713) from the shipment into the Powder Die.

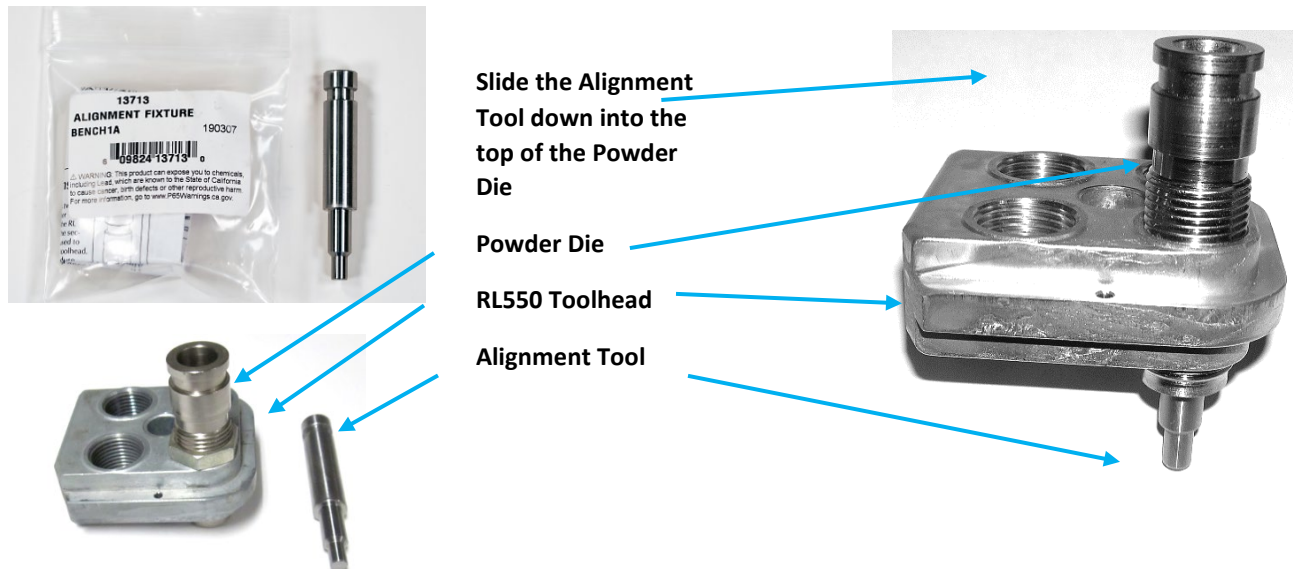

**6.3.4** Re-attach the RL550 Platform (with the RL550 Casefeeder Housing/Assembly attached) to the RL550 Mainshaft with the two Socket Head screws previously removed, making sure to sandwich the Failsafe Return Bracket between the Platform and the Mainshaft. Lightly tighten these two Socket Head Cap Screws. Insert the Toolhead/Alignment Assembly (6.3.3 above) in the RL550 Frame and secure the Toolhead in place with the two Standard Toolhead Pins.

Reinstall the RL550 Platform with RL550 Case Feeder Assembly PN96002 on the RL550 Mainshaft and lightly tighten the Two mounting SHCS

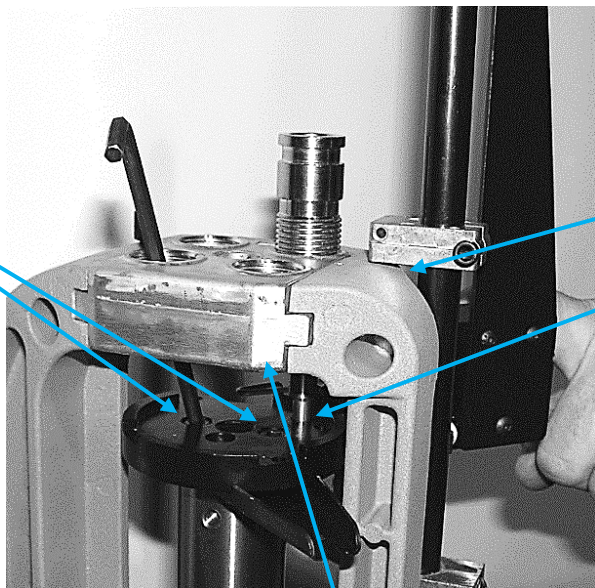

Reinstall Failsafe Return bracket between Platform and Shaft

Powder Die

Alignment Tool sticking out of bottom of Powder Die into Primer Hole in Platform

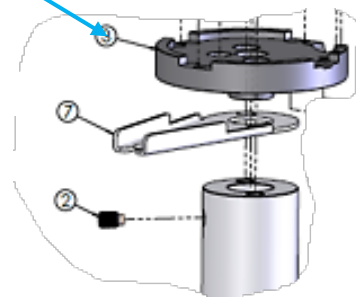

Insert the RL550 Toolhead, Powder Die and Alignment Assembly into the RL550 and secure it with standard Alignment Pins

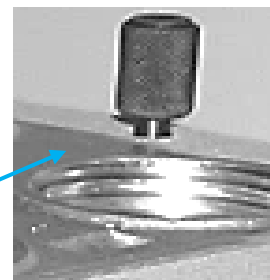

**6.3.5** Slowly lower the Operating Handle while “wiggling” the Platform to guide the small diameter end of the Alignment Tool into the Primer Punch Hole in the Platform. Cycle the Operating Handle up and down to verify the alignment has been accomplished and that the Alignment Tool slides freely in and out of the Primer Punch Hole. Firmly tighten down the two Screws. After tightening the screws, verify the alignment tool still slides freely in and out of the Primer Punch Hole. Do not remove the Alignment Toolhead yet.

Firmly tighten both Socket Head Cap Screws (SHCS)

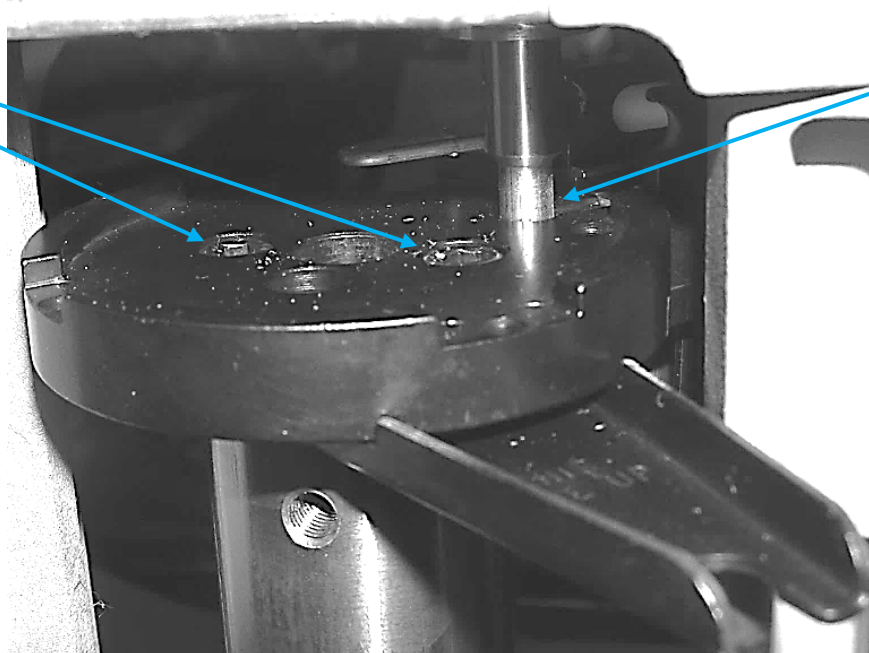

Rotate Platform back and forth guiding the Small End of the Alignment tool into the Primer Hole in the Platform

## 6.4 Reinstall the Primer System

- 6.4.1 Retrieve the Primer Assembly that was removed. Cycle the Operating Handle partially down raising the Platform and place the Primer Slide on the Track Bearing. Slowly raise the Handle up to its at-rest position, which lowers the Platform while “wiggling” the slide back and forth to center the Primer Cup in the Hole in the Platform.

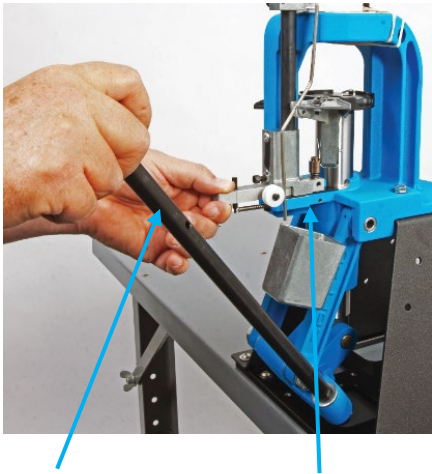

Raise the Handle lowering the Platform while a (wiggling) the Primer Slide back-and-forth to align/center the Primer Cup in the Hole in the Platform

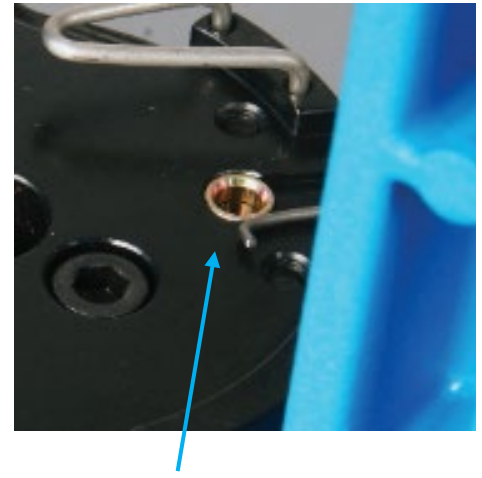

Center Primer Cup in Hole in Platform—slides freely up and down

- 6.4.2 Lower the Primer Feed body Assembly into place and loosely fasten it in its position with the two screws previously removed. Do not tighten these screws yet. Gently cycle the Operating Handle to the priming position, while centering the Priming Cup in the Platform. Hold the Handle fully back, fully compressing the Primer Punch Spring. Wiggle the Primer Slide and Feed body around within the clearance in the mounting holes to make sure there is no binding of the Priming Cup (Gold or Silver) in the Platform/Shellplate by partially cycling the Handle up and down. Gently tighten the two Mounting Screws no more than 1/8 of a turn past finger tight with a 7/32" Allen Wrench with the Operating Handle again held firmly fully back. Overtightening these screws may damage the Primer Feed Body and/or bind the Primer Slide. Verify that the newly installed RL550 Lower Casefeed Assembly does not contact the Primer Feed Body on the priming stroke. If it does loosen and rotate the Platform counterclockwise slightly and retighten with the Alignment tool still engaged with the Platform. Again, verify the Alignment Tool still slides freely in and out of the Platform. Now, remove the Tool Head with the Alignment Tool.

Lower the Feed Body Assembly over Primer Slide Assembly



Push Handle fully to the rear while centering the Primer Cup in the Platform and aligning the Feed Body on the two screws

Tighten the screws no more than 1/8 turn past finger tight—*overtightening will damage the Feed Body*

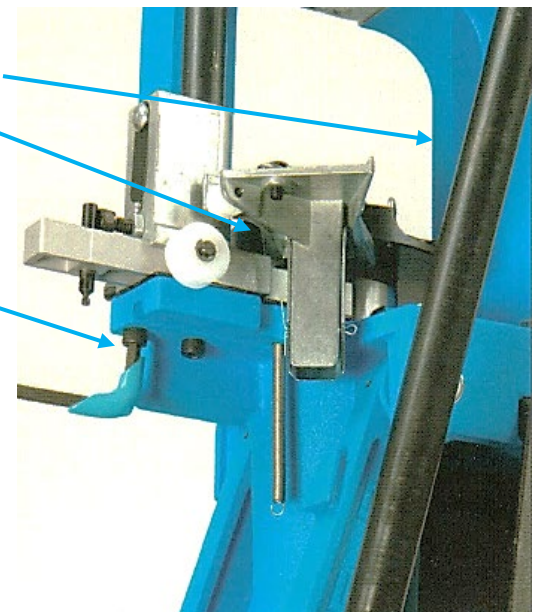

**6.4.3 Replace the Operating Rod in the Operating Rod Bracket and position it between the Two White Rollers and reconnect the Primer Slide Return Spring.**

Lightly grease top bent leg of the Operating Rod

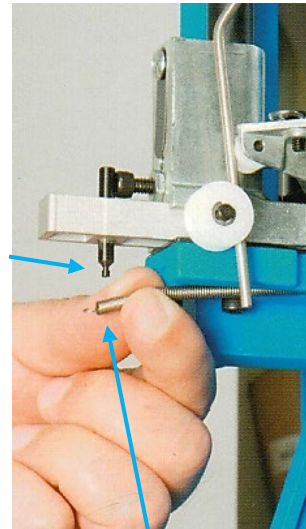
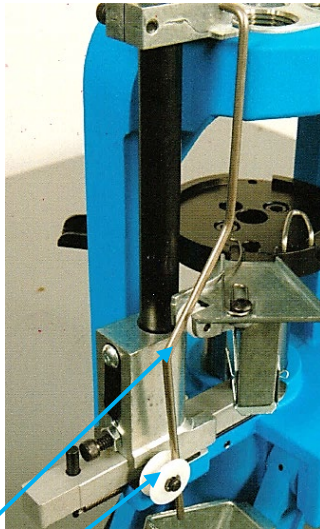
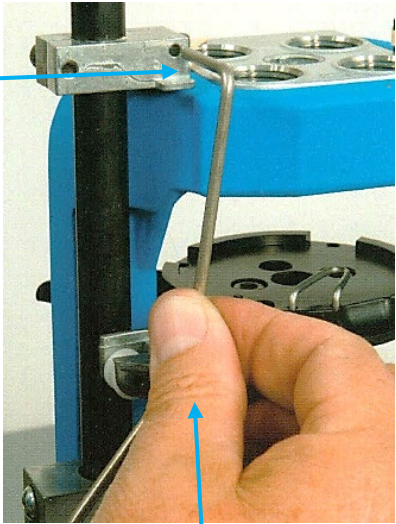

Re-install the Operating Rod into the Rod Bracket and between the two White Rollers

Re-connect the Primer Slide Return Spring

**6.4.4 Hold the Operating Handle halfway down. Pull the spring-loaded Primer Slide out and position the Operating Rod so that it is aligned in the upper Small White Roller and the lower Large White Roller as shown below. Cycle the Operating Handle down and back up. The Slide should move back-and-forth smoothly.**

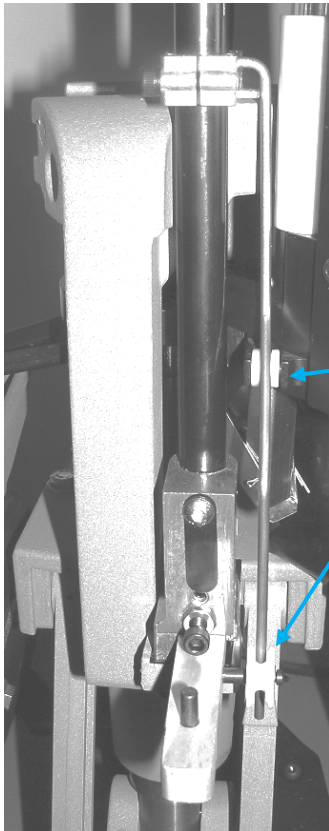

Align Primer Slide Operating Rod in upper and lower White Rollers as shown

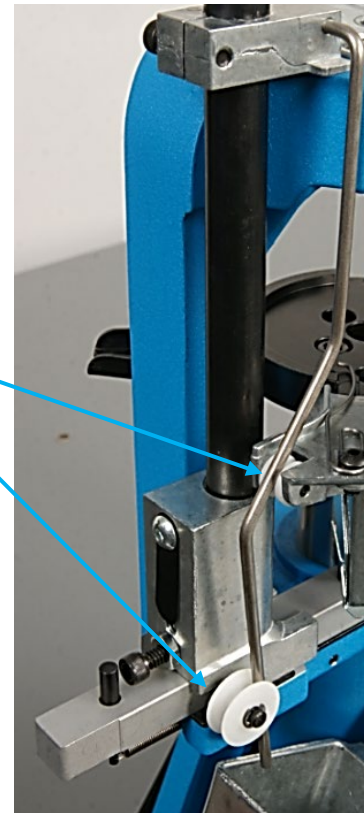

## 6.5 Install the Casefeed Bowl Support and Casefeed Cam Assembly

- 6.5.1 Remove the existing rear RL550 Mounting Screws and the right front mounting Screw holding the RL550 Frame down to the strong mount or bench. Install the left side of the CF Post Support (PN18907 or PN 18923 (New Support) using one of the previously removed RL550 Mounting Screws, Nuts and Washers finger tight.

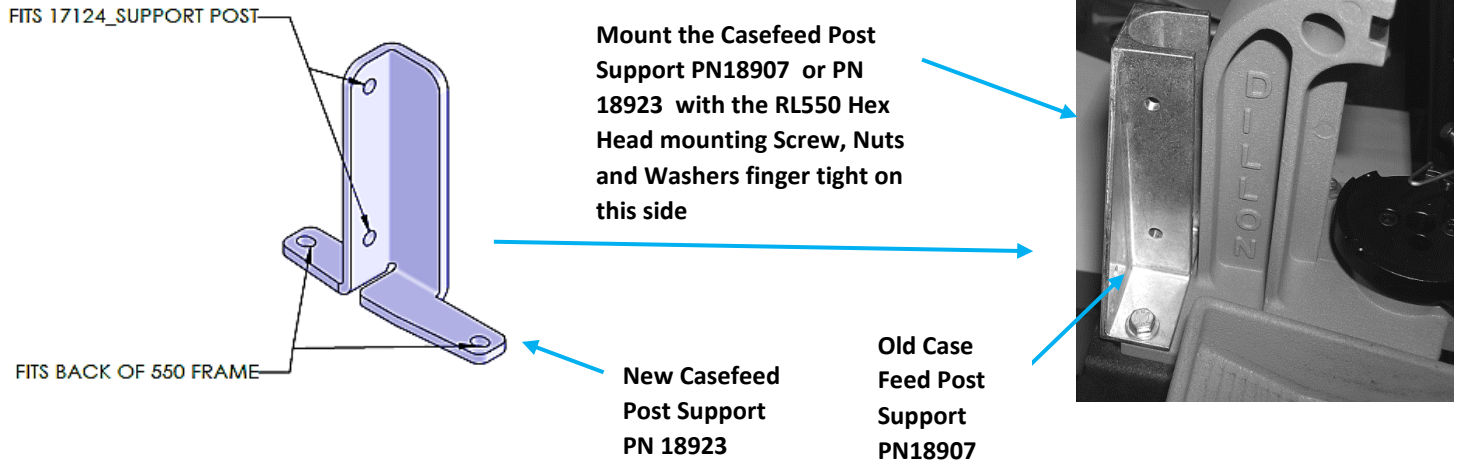

- 6.5.2 Use a Powder Die to support the Platform at the approximate installation height needed for the Cam (PN installation and adjustment as shown below.

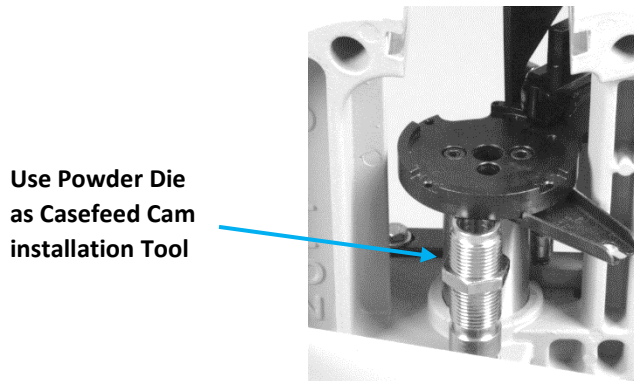

- 6.5.3 Align and fasten the rear mounting slot of the RL550 Casefeed Cam (PN18911) to the Right Rear Mounting Hole in the RL550 Frame. Fasten with the RL550 Frame 1/4 -20 Hex Screw, Washer and Nut previously removed finger tight. Pull the plunger back and rotate the RL550 Cam into position so the Front Mounting Slot on the Cam aligns with the Front Mounting Hole in the Frame and reinstall the 1/4 -20 bolt previously removed, and finger tighten the nut (FIG 11).

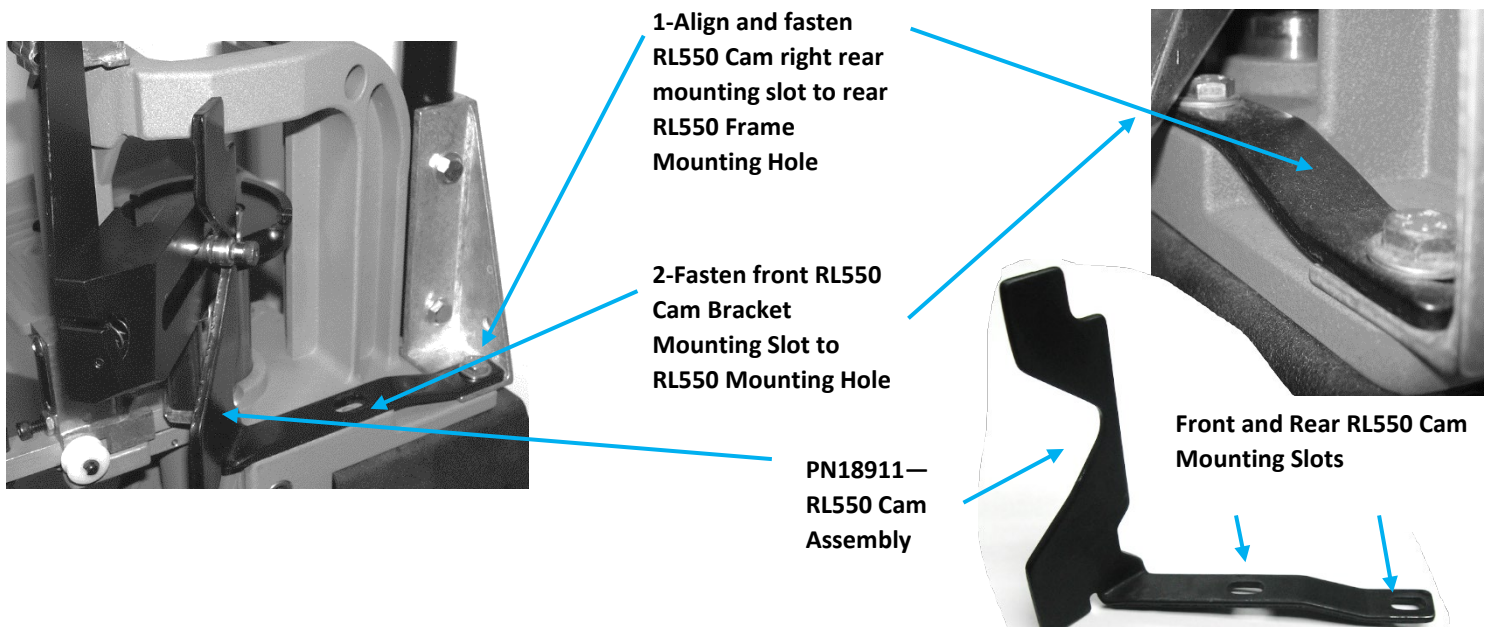

**6.6 Align and adjust the RL550 Cam as follows:**

- 6.6.1 Push the RL550 Casefeed Cam to the back.
- 6.6.2 Lower the Operating Handle so that the Casefeed Plunger Roller is in the center of the flat on the Cam.
- 6.6.3 Slide the Cam forward until it just touches the Roller and tightens the two Mounting Bolts on the Cam (be sure not to release the handle until they are tightened).
- 6.6.4 Make sure that the Roller on the Plunger is centered on the Cam and tighten the Mounting Bolts. Cycle the Operating Handle a few times and make sure the Case Feed Plunger operates freely—adjust as required.

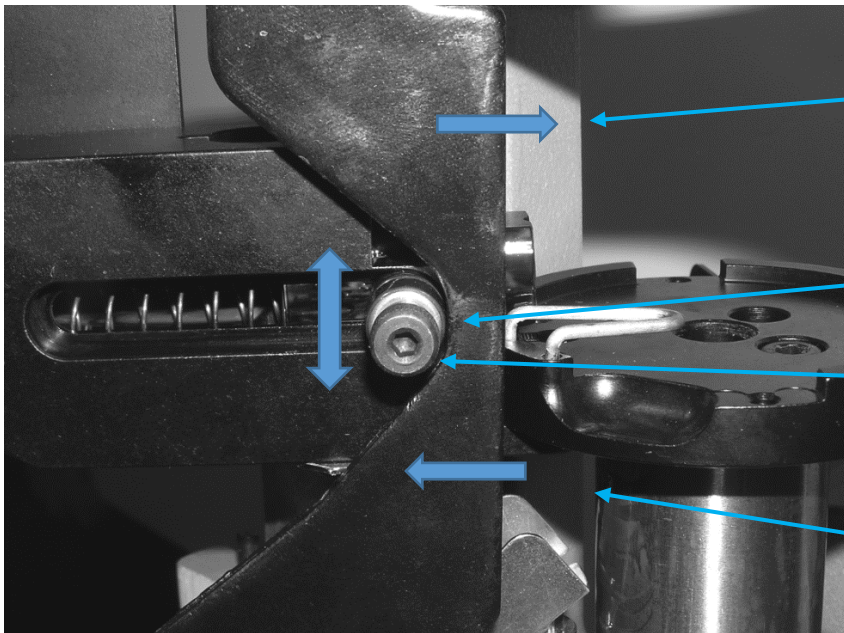

1-Slide RL550 Cam all the way to the rear

2-Lower the Operating Handle of the RL550 until Roller is centered in the Flat of the Cam

3-Slide the RL550 Cam forward until it just touches the Roller and tighten Hex Mounting Screws

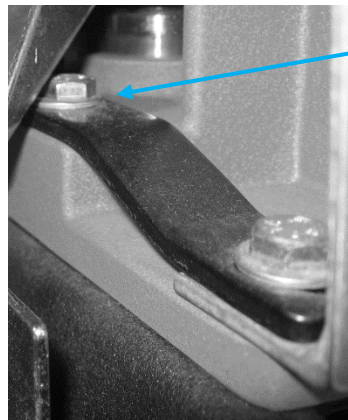

**6.7 Install the Casefeed Support Post into the Case Feed Support Bracket with the two supplied ¼-20x1.75 Hex Screws, Washers and Nuts (supplied in the Hardware Bag). Position the curve in the Post to the right and tighten it securely.**

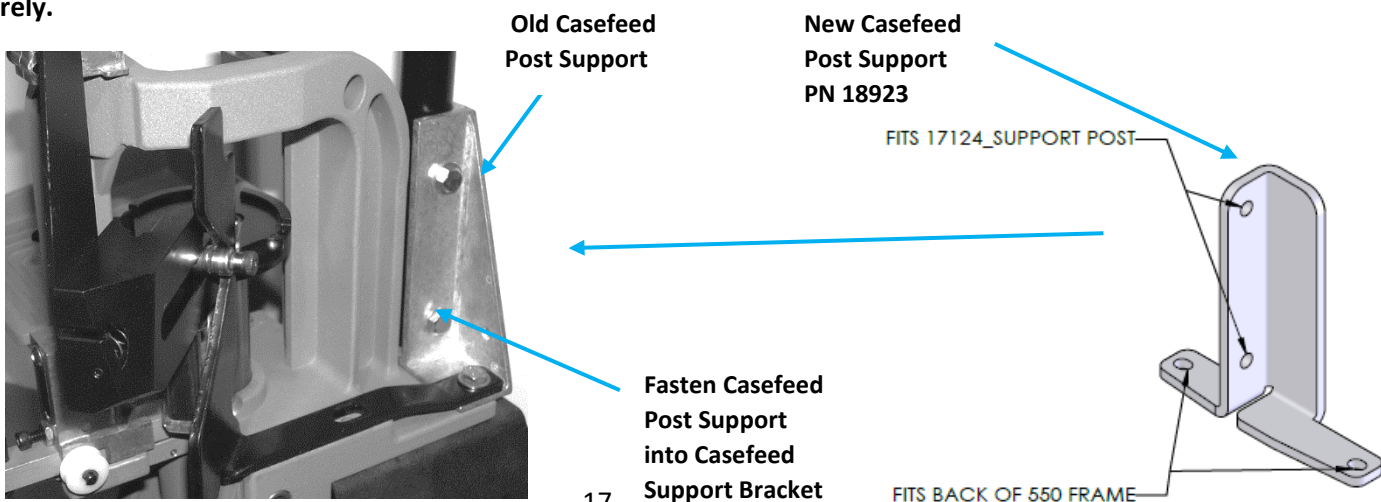

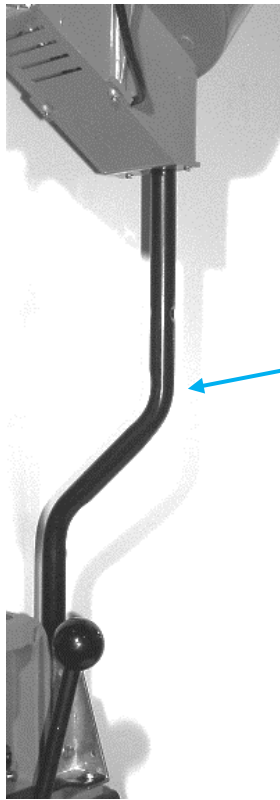

Position the Casefeed Post Support with the Curve section to the right

**6.8 Install the 1/4-20 Screw on the side of the Casefeed Bowl. Slide the Casefeed Bowl over the Casefeed Mounting Post and finger tighten the 1/4-20 Screw so that it Casefeed Bowl can still rotate for subsequent alignment.**



Install 1/4-20 Screw



Slide Casefeed Bowl over the Mounting Post

**6.9 Install the Casefeed Adaptor (from the conversion kit purchased separately for the specific caliber) into the mounting hole on the 550 CF Lower Feeder Assembly. Make sure to align the notch on the Adaptor with the corresponding slot in the Casefeed Housing.**

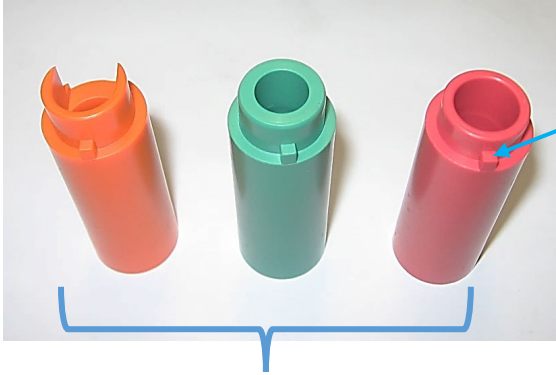

**Typical Casefeed Adaptor—  
Orange, Green and Red**

**Align Casefeed  
Adaptor notch with  
corresponding slot  
in Casefeed  
Housing**

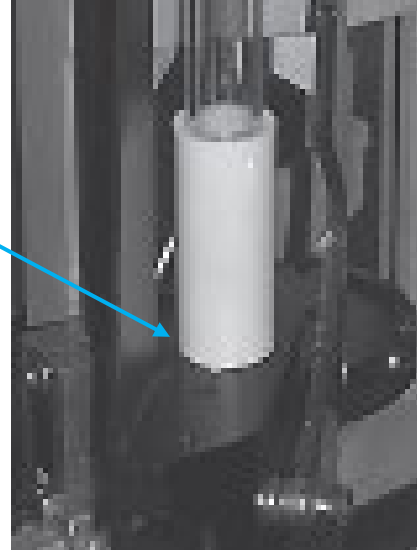

**6.10 Insert the Lower Casefeed Tube into the counterbore at the top of the Casefeed Adapter then snap the middle of the Lower Casefeed Tube into the Spring Clamp on the top of the 550 Casefeed Assembly.**

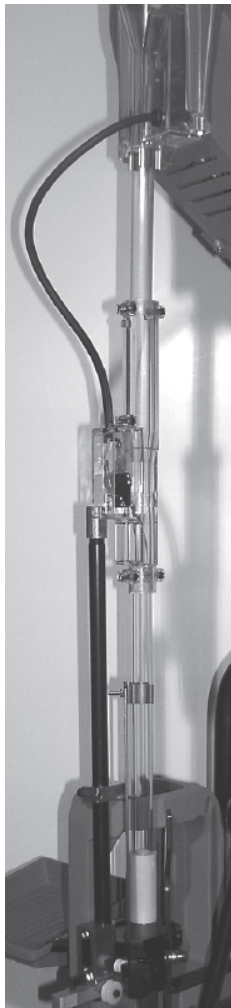

**Snap Lower  
CF Tube into  
Spring Clamp  
on bracket of  
the Casefeed  
Assembly**

**Insert the  
bottom of  
Lower CF  
Tube into  
Casefeed  
Adapter**

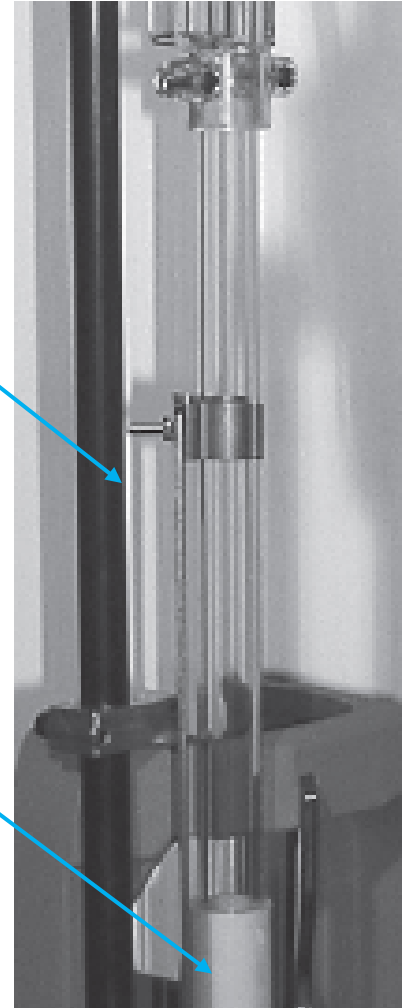

**6.11 Install the 550 Casefeed Switch Housing/Feed Tube on the Lower Casefeed Tube and install the Upper Casefeed Tube into the top of the Switch Housing and snap the Upper Flanged End of the Upper Casefeed Tube into the Spring Clip on the Casefeed Funnel while aligning the Casefeed Funnel/Bowl with the RL550 Case Feed Lower Feed Tube Assembly.**

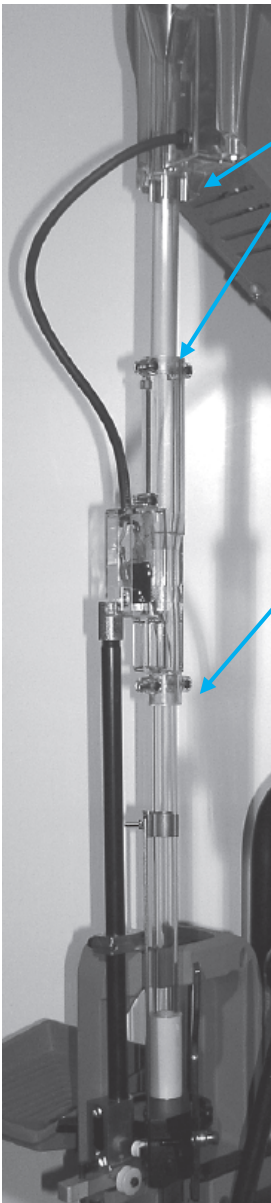

**2-Rotate/align the Casefeed Bowl so that the Funnel Spring Clip aligns with the Switch Housing**

**1-Slide the Switch Housing Feed Tube of the 550 Case Feed Bowl Assembly over the top of the Lower Case Feed Tube**

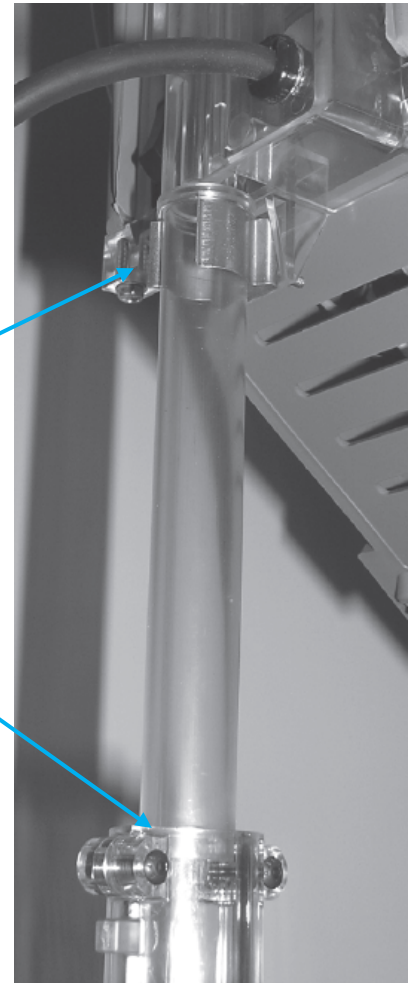

**3-Slide the bottom of Upper Case Feed Tube into the top of the Switch Housing and snap the flanged Top of the Upper Case Feed Tube into the Spring Clip on the Case feed Funnel**

**4-Tighten 1/4-20 Screw on Casefeed Bowl**



**5-Install the caliber specific Casefeed Plate engaging the Drive Tee of the Motor with the hole and slot in the bottom of the Casefeed Plate**

**Casefeed Plate Drive "Tee"**

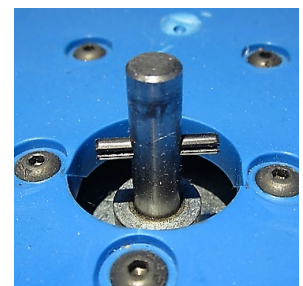

**6.12 Install the new Cartridge Chute with the Hardware previously removed.**

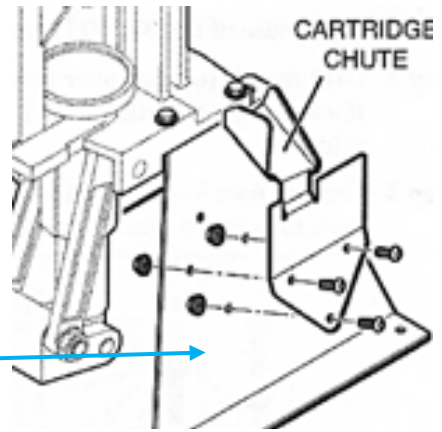
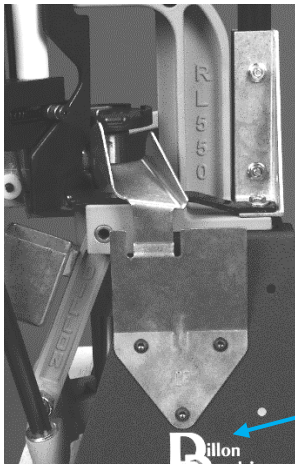

Install the Cartridge Chute Bin Bracket

**6.13 Install the Caliber Specific Station 1 Locator from the Conversion Kit (purchased separately) in the cavity in the Casefeed. Make sure it is seated and flush with the Platform as shown below.**

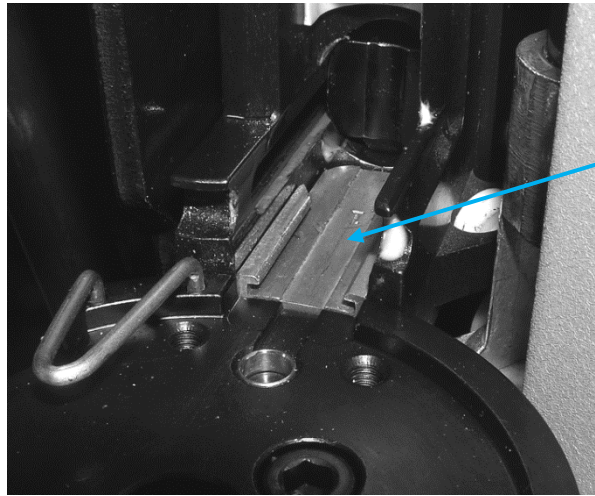

Install Station 1 Locator--

**6.14 Carefully install the Index Ball Spring and Index Ball in the hole in the Platform as shown, being careful not to drop the Spring or the Ball in the Shellplate Bolt Hole. Place the Shellplate on the Platform, number side up.**

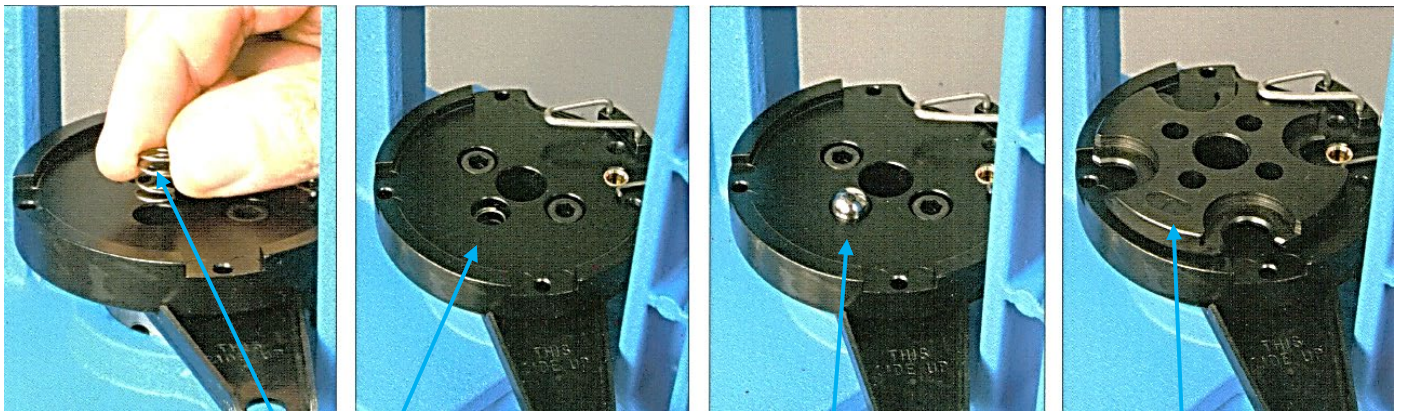

Index Spring

Index Ball sitting on Spring

Shellplate—number up

**6.15 Place the Index Sprocket with the four-round bosses on the bottom in the mating holes in the top of the Shellplate. Insert the Shellplate Bolt carefully down through the Index Sprocket and Shellplate and thread the Bolt**

down into the Mainshaft. Snug the Shellplate Bolt down against the Shellplate and back it up 1/16 to 1/8 of a turn. Verify that the Shellplate turns freely and there is minimal clearance between the Shellplate and Platform—adjust as necessary. Also, make sure none of the Four Index Sprocket Arms drag on the Ejector Wire. Note—the Ejector wire can be adjusted up or down. Tighten the Shellplate Bolt Brass Tipped Locking Set Screw. Not tightening the Locking Set screw will allow the Shellplate to rotate the Shellplate Bolt and stop the Shellplate from turning during normal operation.

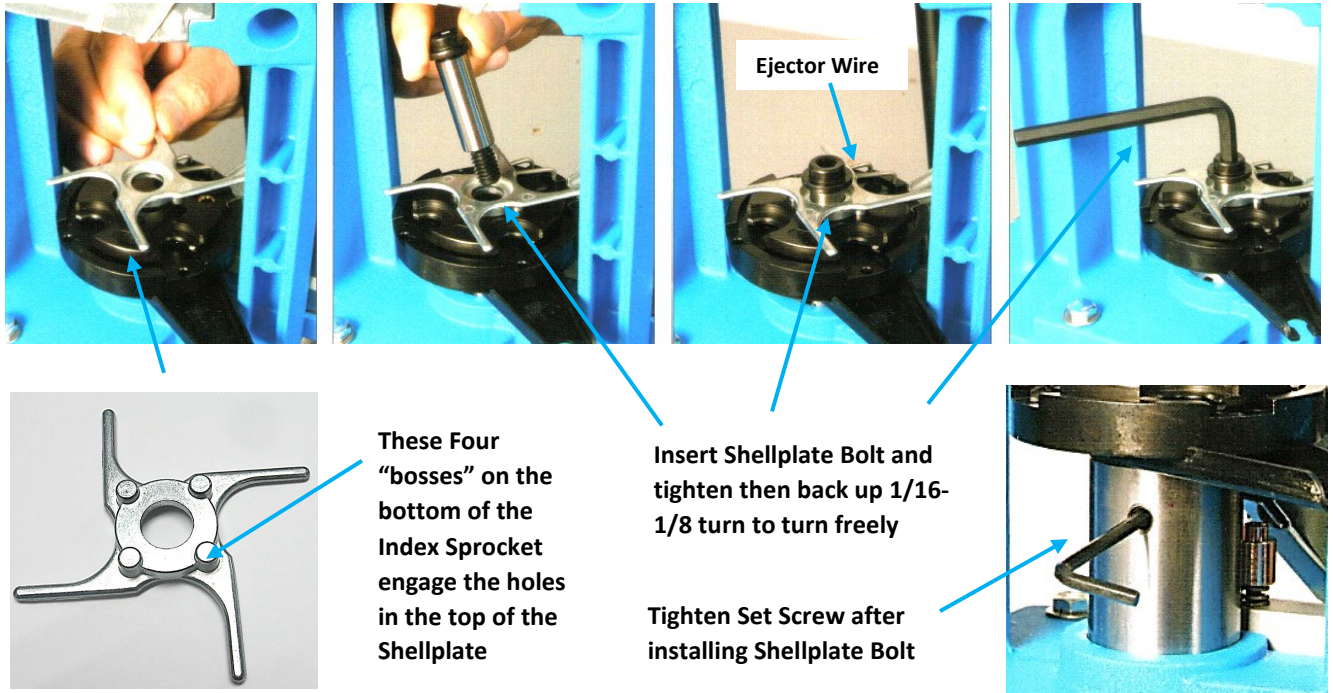

**6.16 Reinstall the Locator Buttons as shown below.**

Reinstall Locator Buttons



**6.17 Reinstall the Powder Measure**

**6.17.1** Slide the Powder Measure down over the Powder Die and tighten the two clamp screws.

Place Powder Measure on Powder die

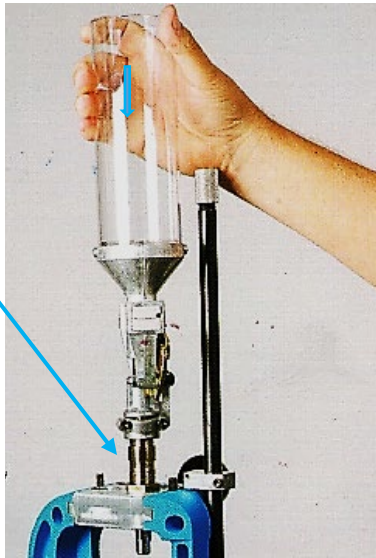

Tighten the Powder Measure Clamp Screws

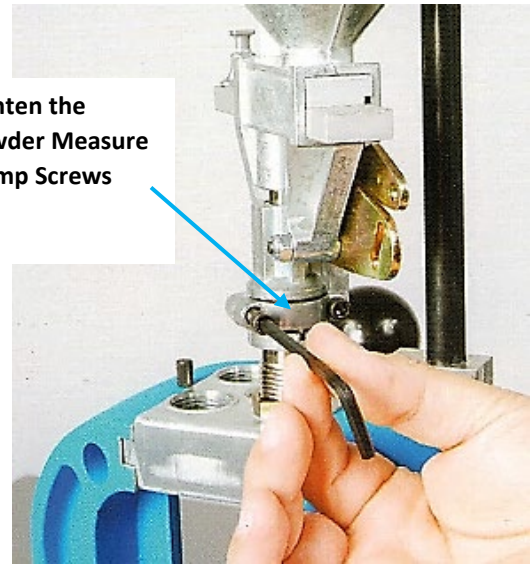

6.17.2 Install the bent end of the Powder Measure Failsafe Rod through the slot and hole in the Lock-Link Assembly oriented as shown below.

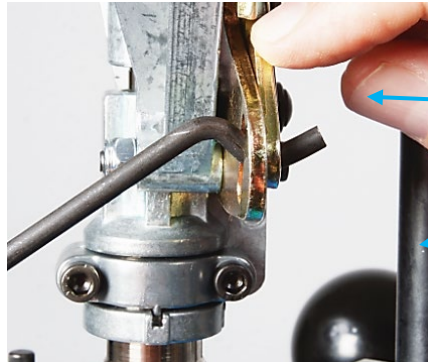

Lock-link Assembly

Install upper end of the Failsafe Rod in the Lock Link Assembly

- Rotate the Powder Measure, aligning the Failsafe Rod vertically with the Failsafe Rod Bracket as shown below. Gently snap the white Failsafe Rod Bushing into the Failsafe Rod Bracket from the bottom up. Cycle the Operating Handle down and up fully to the back, compressing the Failsafe Rod Spring. Adjust the blue Wing Nut up leaving .030" of clearance (two credit card thicknesses) between coils when fully compressed. Re-adjustment may be necessary after setting the case mouth belling for pistol cases and the Powder Funnel to case contact on rifle cases described later.

Push Failsafe Rod Bushing up into the Failsafe Rod Bracket



Tighten the Blue Wingnut with the Operating Handle down and the Spring compressed—leave a .030" gap between the coils-- (thickness of two credit cards).

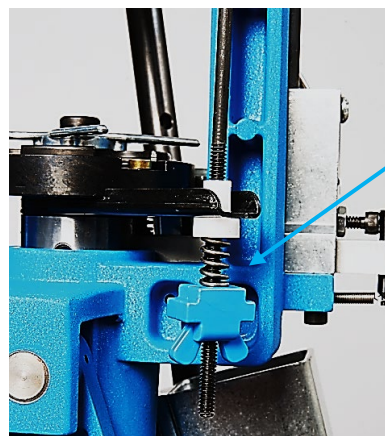

6.18 Gently cycle the Operating Handle down and up again and push the Handle fully to the back to the priming position. The Primer Slide should move smoothly forward. The Primer Punch should be smoothly projected up

through the hole in the Platform into the Shellplate. The Casefeed Plunger should move freely forward and back. Your assembly is complete.

**7 SETUP PROCEDURES FOR RL550C Casefeeder—*WARNING! DUE TO VARIATIONS IN COMPONENTS, CHECK ALL STATIONS FOR PROPER ADJUSTMENTS FOR THE CARTRIDGE BEING LOADED ANY TIME YOU CHANGE ANY COMPONENTS. IF THERE IS SOMETHING YOU DO NOT UNDERSTAND, CALL (800) 223-4570 FOR TECHNICAL ASSISTANCE.***

**7.2 Casefeeder Adjustment**

**Casefeed Plate Selection, Casefeed Window Cuff Position and Case Deflector Block Adjustment Chart**

The chart below outlines the recommended Casefeed Plate and starting positions for the Casefeed Window opening position and Case Deflector Block position. Adjustment to the window position and Case Deflector may be necessary dependent upon the variation of your setup. The illustration at right shows the Casefeed Window opening positions from 1 to 6 as listed below. Start with the Variable Speed Control Knob at its mid position and adjust up or down to match the RL1100 cycle rate.

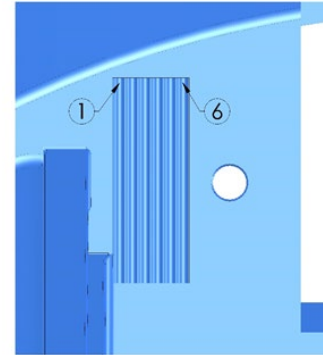

CALIBER	CASEFEED PLATE	WINDOW POSITION	DEFLECTOR POSITION
.30 Luger, .30 Mauser	SMALL PISTOL	#3	DOWN
.32 ACP, 7.65MM	SMALL PISTOL	#3	DOWN
.32 S&W	SMALL PISTOL	#3	DOWN
.32 H&R Magnum	SMALL PISTOL	#3	DOWN
.327 Federal Magnum	SMALL PISTOL	#3	DOWN
7mm TCU	SMALL PISTOL	#3	DOWN
9mm, 9x21, .38 Super	SMALL PISTOL	#3	DOWN
9x18 Makarov	SMALL PISTOL	#3	DOWN
9x25 Dillon	SMALL PISTOL	#3	DOWN
.380 ACP	SMALL PISTOL	#3	DOWN
.38 Super Comp	SMALL PISTOL	#3	DOWN
.38 Special,	LARGE PISTOL	#3	DOWN
.357 Magnum	LARGE PISTOL*	#3	DOWN
.357 SIG	LARGE PISTOL	#3	DOWN
10mm	LARGE PISTOL	#3	DOWN
.40 S&W	LARGE PISTOL	#3	DOWN
.41 Mag.	LARGE PISTOL	#3	DOWN
.44 Special, .44 Magnum	LARGE PISTOL	#3	DOWN
.45 ACP	LARGE PISTOL	#3	DOWN
.45 GAP	LARGE PISTOL	#3	DOWN
.45 Auto Rim	LARGE PISTOL	#3	DOWN
.45 Colt/S&W, .454 Casull	LARGE PISTOL	#3	DOWN
.45 Win. Mag.	LARGE PISTOL	#3	DOWN
.300 Blackout	SMALL RIFLE	#6	DOWN
ITEMS WITH "*" REQUIRE THE SPACER WASHER (PART# 13703) BETWEEN THE CLUTCH AND PLATE			

**7.2.1 Casefeed Port Cuff--**The Casefeed Window Cuff is adjustable. This allows for faster and more dependable Casefeeding of longer and shorter rifle cases. The window has six positions; the third position from the left is the standard opening width of the previous unit. This adjustment should work for all pistol and most standard rifle cartridges. The window

adjusted to the full left position (fully open) allows for faster Casefeeding of larger rifle calibers. The window adjusted to the full right position allows for Casefeeding of shorter bottleneck rifle cases (i.e., 300AAC Blackout, 7.62x39) utilizing standard rifle Casefeed Plates. Adjust the Cuff by loosening the black knurled nut, which incorporates a 3/16" socket hex. Slide the Cuff into the desired position, making sure that the small leg is locked into the adjustment notch. Retighten the nut to no more than 10-12 in.-lbs. to lock the Cuff in position.

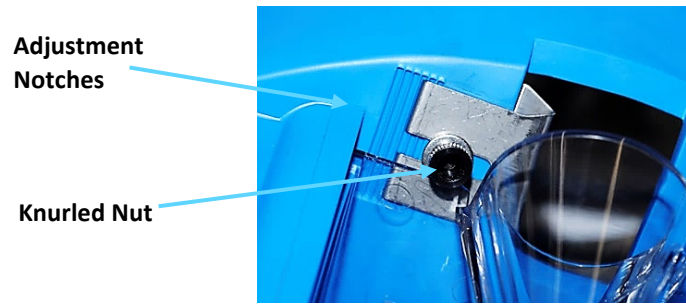

**7.2.2 Case Deflector**--The Casefeed utilizes an adjustable Case Deflector Block. The Deflector has two positions for operation, fully lowered for pistol and fully raised for rifle cartridges. The block can be adjusted by loosening the two #8 Screws with a 3/32" hex wrench and slide the Block to the desired position based on pistol or rifle cartridges. Lock the Block in position by tightening the two Screws to no more than 5-7 in.-lbs.



**7.2.3 Casefeed Plate Spacer Washer**--Some calibers require a spacer under the Casefeed plate. Refer to the caliber conversion chart Section 7.1. Installation of this added washer raises the plate for longer pistol cases. To install the Washer, remove the Casefeed Plate from the Casefeeder. Disassemble the Casefeed Plate Clutch by removing the two Clutch Screws. During disassembly keep the Washers together on the Screws. Install the Spacer Washer between the Lower Clutch and the Casefeed Plate and reassemble the Clutch. Adjust the Clutch tension as follows in section 7.1.5 below.

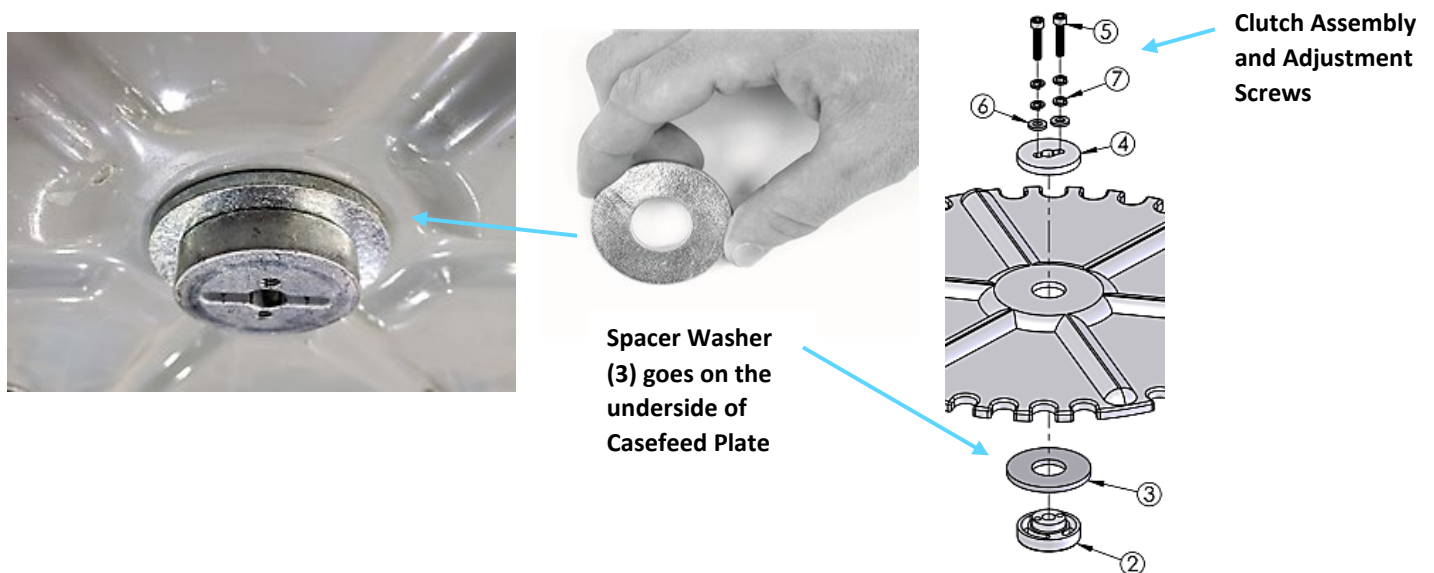

**7.2.4 Clutch Adjustment/Bowl Capacity**--The Clutch comes factory set. If you are experiencing a feeding issue or have installed the Optional Spacer Washer, follow these steps to adjust the Clutch. Fill the Casefeed Bowl no more than half-full of brass. A fully loaded Casefeeder will not function reliably. The two Socket-Head Screws (5 above) are the "clutch" adjustment screws. They should be just tight enough for the Clutch to drive the Casefeed Plate under a normal

load of brass. Note!--With the Casefeeder half full of brass, you should be able to cause the Clutch to slip using moderate finger pressure on the Casefeed Plate, without stalling the Motor. Alternatively, tighten or loosen the two Clutch Screws (5) evenly, observing the effect on the Clutch's holding power. The correct setting will cause the Plate to stall before the Motor stalls, yet not slip when the Casefeed Bowl is no more than half-full of brass.

**7.2.5 Casefeed Power Supply Setup**--The new Variable Speed Casefeeder utilizes a Universal Power Supply that works on 115-240V AC 50/60 Hz and comes with several Wall Socket Adaptors. Choose the Adaptor for the utility power in your area. Install the Adaptor into the Power Supply, by inserting the side with the raised edge opposite the sliding latch and press into the pocket until the latch locks in place (120V AC Adaptor pictured).



**7.2.6** Connect the Power Supply Power Cord to the Casefeeder by pushing the small Barrel Plug Adaptor into the Socket on the bottom face of the Casefeeder. Now plug in the Power Supply.



**7.2.7** The Casefeeder's speed is adjustable up to 8 RPM. Rotating the Dial fully counterclockwise will set the Motor at the lowest speed and rotating clockwise will set the Motor at its full speed. Start with the Dial in the middle of its rotation (about 4 rpm). Turn the Power Switch to the on position. Fine-tune the Motor speed rpm to optimize case feeding.

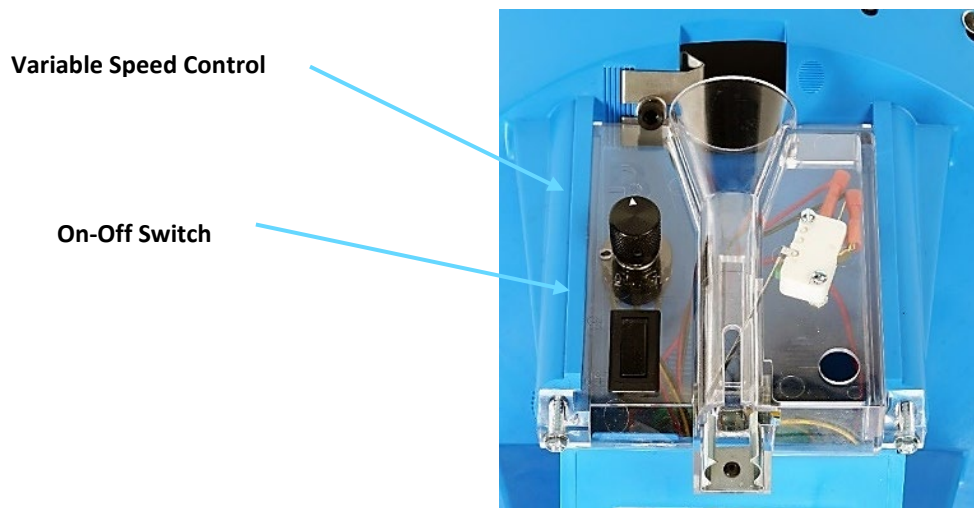

## 8 CONVERSION LIST AND PROCEDURES

**8.1** Dillon has conversion kits for various calibers as noted in the table below:

<b>RL550 CASEFEED CONVERSIONS</b>				<b>Avialable Calber Compents</b>		
<b>CONVERSION. PART NO.</b>	<b>CALIBER</b>	<b>RL550 STATION 1 LOCATOR</b>	<b>CASE FEED ADAPTOR</b>	<b>SHELL PLATE</b>	<b>LOCATOR BUTTON</b>	<b>POWDER FUNNEL</b>
14206	.25-20 WIN	W ( 14225 )	BLUE (13075)	O (12013)	3 (14060)	R (13243)
14284	.30 LUGER	5 ( 14224 )	GREEN (13450)	5 (13743)	3 (14060)	C (13564)
14204	.30 MAUSER/7.62x25	5 ( 14224 )	RED (13143)	5 (13743)	3 (14060)	C (13564)
62226	.300ACC BLACKOUT	3 (14227)	BLUE (15186)HORNET	3 (13684)	3 (14060)	AK(13015)
14205	.32 S&W LONG	D ( 14223 )	GREEN (13450)	D (13092)	3 (14060)	SW (13171)
14283	.32 H&R MAG	D ( 14223 )	BLUE (13075)	D (13092)	3 (14060)	SW (13171)
14206	.32-20 WIN	W ( 14225 )	BLUE (13075)	O (12013)	3 (14060)	S (12845)
14284	9 MM / 9x21 / .38 SUPER	5 ( 14224 )	GREEN (13450)	5 (13743)	3 (14060)	F (13806)
14285	9x25 DILLON	W ( 14225 )	RED (13143)	5 (13743)	2 (14062)	F (13806)
14287	.38 SUPER COMP.	3 (14227)	GREEN (13450)	3 (13334)	3 (14060)	F (13806)
14208	.38 S&W	2 (14226)	PURPLE (18076)	U (12944)	2 (14062)	F (13806)
14286	.38 SPL.	2 ( 14226 )	ORANGE (13386)	2 (13751)	2 (14062)	D (13599)
14289	.357 SIG	W ( 14225 )	PURPLE (18076)	5 (13743)	2 (14062)	F (13806)
14286	.357 MAG	2 ( 14226 )	ORANGE (13386)	2 (13751)	2 (14062)	D (13599)
14288	.38-40 WIN	N ( 14228 )	YELLOW (13442)	N (10004)	4 (14047)	W (13600)
14292	.40 SUPER	1 ( 14231 )	RED (13143)	1 (13692)	1 (13930)	W (13600)
14292	.400 COR-BON	1 ( 14231 )	RED (13143)	1 (13692)	1 (13930)	W (13600)
14289	.40 S&W	W ( 14225 )	PURPLE (18076)	5 (13743)	2 (14062)	W (13600)
14285	10 MM	W ( 14225 )	RED (13143)	5 (13743)	2 (14062)	W (13600)
14290	.41 MAG.	6 ( 14229 )	YELLOW (13442)	6 (13120)	1 (13930)	H (13240)
14288	.44-40 WIN	N ( 14228 )	YELLOW (13442)	N (10004)	4 (14047)	4 (13474)
14291	.44 COLT	4 ( 14230 )	YELLOW (13442)	4 (13610)	1 (13930)	G (13427)
14209	.44 RUSSIAN	4 ( 14230 )	RED (13143)	4 (13610)	1 (13930)	G (13427)
14291	.44 SPL. / 44 MAG.	4 ( 14230 )	YELLOW (13442)	4 (13610)	4 (14047)	G (13427)
11441	.45 GAP	1 ( 14231 )	GRAY (12670)	1 (13692)	1 (13930)	E (13782)
14292	.45 ACP/.40 SUP/.400Cr-Bn	1 ( 14231 )	RED (13143)	1 (13692)	1 (13930)	E (13782)
14279	.45 S&W SCHOFIELD	C ( 14232 )	YELLOW (13442)	C (13334)	4 (14047)	E (13782)
14279	.45 COLT	C ( 14232 )	YELLOW (13442)	C (13334)	4 (14047)	E (13782)
14210	.45 WIN MAG.	1 ( 14231 )	YELLOW (13442)	L (12703)	1 (13930)	E (13782)
14279	.454 CASULL	C ( 14232 )	YELLOW (13442)	C (13334)	4 (14047)	E (13782)
19140	45 AUTO RIM	UNIVERSAL (19139)	RED (13143)	H (13010)	4 (14047)	E (13782)

\*\* CONVERSION PART NUMBERS ONLY CONTAIN THE STATION 1 LOCATOR AND THE CASE FEED ADAPTOR \*\*

550 CASE FEED WILL NOT WORK ON RIFLE CALIBERS, INCLUDING 30 CARBINE & 22 HORNET

550 CASE FEED STATION 1 LOCATORS ARE NOT THE SAME AS 650750 STATION 1 LOCATORS

## 8.2 Caliber Conversion Procedure for the RL550 Casefeeder.

- 8.2.1 Obtain the available RL550 Conversion Kit according to the 550 Case Feed Caliber List above in 8.1. Replace the Station 1 Locator and the Casefeed Adapter.



**Typical 550 CF Caliber Conversion Kit-**

- 550 Station 1 Locator
- Case Feed Adaptor

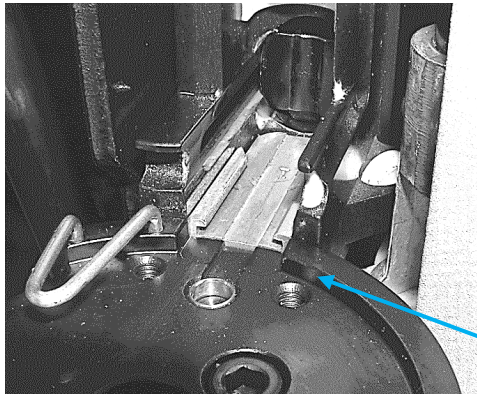

Replace Align Casefeed Adaptor aligning notch with corresponding slot in Casefeed Housing

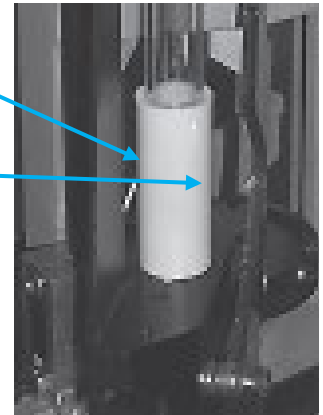

Replace Station 1 Locator--

**8.2.2 Obtain and replace the Casefeed Plate if required referring to Table 7.2 above.**



Casefeed Plate engages Plate Drive "Tee"—sits flush on bottom of Bowl

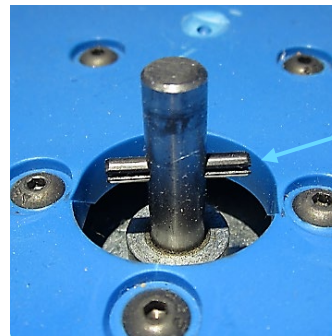

Casefeed Plate Drive "Tee" in Motor Shaft

**8.2.3 Obtain an available RL550 Caliber Conversion Kit for the caliber and install it according to the RL550C Manual**



Typical RL550C Conversion Kit—needs to be ordered separately

**er Conversion Procedures for the Shellplate, Powder Measure and Automatic Primer Systems.**

## 9 TROUBLESHOOTING GUIDE RL550 CASEFEEDER

No.	Category	Issue	Corrective Action
1	Casefeed Issues	9mm cases may flip sideways in the Clear Casefeed Funnel	<ol style="list-style-type: none"> <li>1. Adjust the Casefeed Window as described in the Casefeed Setup Section 7.1 Lower the speed of the Casefeed Motor</li> </ol>
		Cases are having trouble being inserted into the Shellplate. Cases will not enter the slot in the Shellplate	<ol style="list-style-type: none"> <li>1. Tighten/minimize the clearance between the Shellplate. Test by pushing down on the edge of the Shellplate. If there is excessive clearance (feels springy), tighten the Shellplate Bolt and the Side Locking Set Screw.</li> <li>2. Verify there are no corn cob particles in the Shellplate Pockets or under Shellplate.</li> <li>3. Verify the correct Casefeed Adapter is being used.</li> <li>4. Slow down the cycling rate.</li> <li>5. Damaged Shellplate. --Replace</li> <li>6. Dirty, wrong, worn or damaged Casefeed Plunger. --Clean and or replace.</li> <li>7. Damaged or dirty top sliding surface of Station 1 Locator—Clean or replace.</li> </ol>
		Casefeeder is on but Casefeed Plate does not rotate	<ol style="list-style-type: none"> <li>1. Brass may be caught under the Casefeed Plate, in the Casefeed window or Casefeed Deflector.</li> <li>2. The Casefeed Bowl is over full.</li> <li>3. The Casefeed Plate is not fully seated on the Drive Motor Shaft.</li> <li>4. A bad Microswitch or Microswitch Lever caught on the inside of the Tube.</li> <li>5. The Clutch is slipping. --Adjust clutch per Casefeeder Instructions.</li> </ol>
		Cases are falling upside down.	<ol style="list-style-type: none"> <li>1. Using the wrong Casefeed Plate for that caliber.</li> <li>2. The Window Port Cuff is open too wide. See Casefeeder instructions.</li> <li>3. The Casefeed is too full.</li> <li>4. RL550 is not secured properly, or the bench is not stable.</li> </ol>
		Cases are hanging up on the Microswitch Lever in the Case Feed Tube Switch Housing	<ol style="list-style-type: none"> <li>1. Check the angle of the switch lever and adjust it as needed by gently bending it.</li> </ol>
		The case does not drop into Casefeed Plunger	<ol style="list-style-type: none"> <li>1. Wrong Casefeed Adapter</li> <li>2. Cases jammed in Casefeed Tube/Funnel.</li> <li>3. Tumbling media in Casefeed Tube.</li> <li>4. Case upside down, wrong caliber case mixed in.</li> <li>5. Casefeed Assembly is not adjusted properly.</li> </ol>
		Cases getting crushed between Shellplate and Toolhead	<ol style="list-style-type: none"> <li>1. Cycling the operating Handle too quickly—slow down.</li> <li>2. Case not being pushed all the way into the Shellplate—Check alignment of Station 1 to Shellplate Pocket</li> <li>3. Burrs on new Brass. —Tumble before use.</li> </ol>
		Cases being knocked into Shellplate during the start of loading	<ol style="list-style-type: none"> <li>1. Cases are Falling too far and fast. - Always Lower the Operating Handle raising the Platform all the way up when filling the Casefeed Loading Tube assembly.</li> </ol>
1	Cleanliness	The reloading process is inherently "dirty" due to residue from spent primers, tumbling debris, spilled powder, and metal shavings from trimming within the system. The general reloading process of sizing and seating bullets and primers also generates metal particles. Live primer residue along with leftover Case Lube are other contaminants that need to be cleaned up.	<ol style="list-style-type: none"> <li>1. Compressed air or a "can of air" and a 1" paintbrush are the reloader's "best friends." At the end of a reloading session, blow out the Primer Slide and Shellplate areas. A small paintbrush can be used for cleaning spilled powder which should be cleaned up immediately.</li> <li>2. Periodically clean out the Size, Seat and Crimp Dies with alcohol and swabs. They will get "gooney" over time.</li> </ol>

## 10 RL550C EXPLODED VIEWS AND PARTS IDENTIFIER

### 10.1 Complete Assembly

ITEM	PART #	DESCRIPTION
1	96001	550 CF UPPER BOWL ASSEM
2	18910	550 UPPER CF TUBE
3	18908	550 LOWER CF TUBE
4	18911	550 CASEFEED CAM
5		CASEFEED ADAPTER, NOT INCLUDED
6	96002	550 CF LOWER FEEDER ASSEM
7	14530	550 PLATFORM MOUNTING SCREWS
8	17124	550/900 MOUNTING POST
9	18907	550 CF POST MOUNT, CAST
10	18923	550 CF POST MOUNT, FORMED
11	14457	550 CF MOUNTING HARDWARE

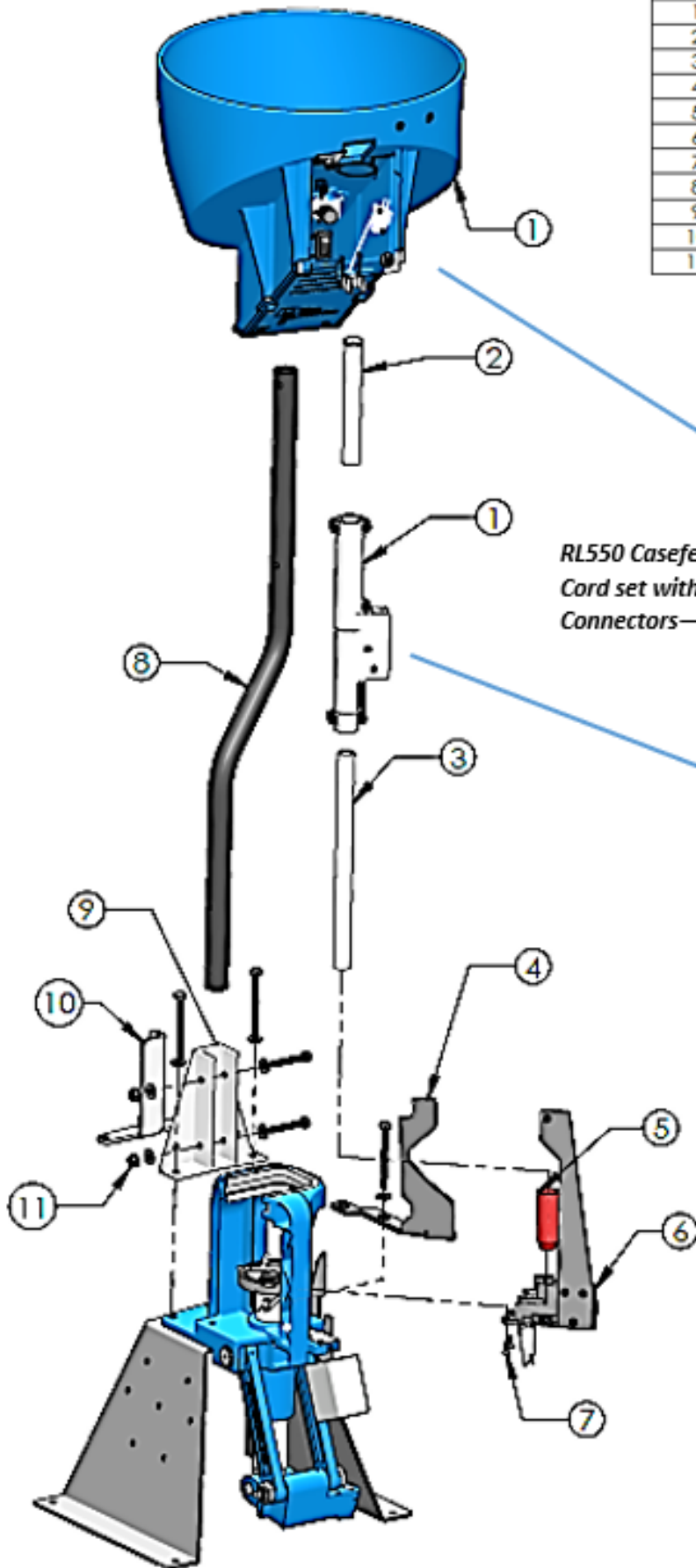

RL550 Casefeed  
Cord set with  
Connectors—



RL550 CF Variable Speed Casefeed  
Bowl Assembly PN96001—Bowl,  
Cord and Switch Housing/Feed tube



Included Variable Speed Casefeed Power  
Supply and Adapters

## 10.2 550 Casefeed Bowl, Controls, Wire Harness and Feed Assembly—PN96001

ITEM	PART #	DESCRIPTION
5		CASEFEED ADAPTER, NOT INCLUDED





550 CF Wire Harness  
with Connectors--  
PN18903

550 CF Upper Assembly  
PN96001

Casefeed Microswitch  
PN13779

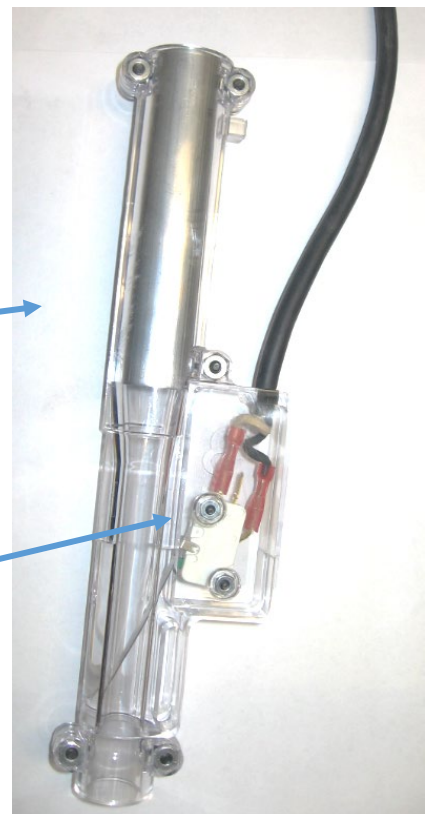

### 10.3 Plate and Clutch Assembly—Parts Identifier

ITEM NO.	PART NUMBER	QTY.
1	13402_LARGE PISTOL CASEFEED PLATE	1
1A	13465_SMALL PISTOL CASEFEED PLATE	
1B	13533_SMALL RIFLE CASEFEED PLATE	
1C	13290_LARGE RIFLE CASEFEED PLATE	
2	13736_CF LOWER CLUTCH	1
3	13703_CF SPACER	1
4	13632_CLUTCH DISC UPPER	1
5	18866_1032 x 875 SHCS CLUTCH SCREW	2
6	13738_SD-B #10 ROD WASHER	2
7	13813_CLUTCH SPRING WASHER	4

DESCRIPTION	
21072_LARGE PISTOL CASEFEED PLATE ASSEMBLY	SEE CONVERSION CHART FOR APPLICABLE SIZE
21073_SMALL PISTOL CASEFEED PLATE ASSEMBLY	
21074_SMALL RIFLE CASEFEED PLATE ASSEMBLY	
21075_LARGE RIFLE CASEFEED PLATE ASSEMBLY	

